



US009737443B2

(12) **United States Patent**
LeMay et al.

(10) **Patent No.:** **US 9,737,443 B2**
(45) **Date of Patent:** **Aug. 22, 2017**

(54) **ERGONOMIC TAMPON APPLICATOR**

(56) **References Cited**

(71) Applicant: **Edgewell Personal Care Brands, LLC**, Chesterfield, MO (US)
(72) Inventors: **Jessica LeMay**, Paramus, NJ (US); **Kathryn Bennett**, Fairfield, CT (US); **Keith Edgett**, Ramsey, NJ (US); **Dane Jackson**, Bloomington, NJ (US); **Mario Turchi**, Tenafly, NJ (US); **Susanne Weber**, New York, NY (US)

U.S. PATENT DOCUMENTS

1,191,736 A 7/1916 Roberson
1,218,478 A 3/1917 Sappington
1,554,690 A 9/1925 Pride
1,555,708 A 9/1925 Gale
1,731,665 A 10/1929 Huebsch
2,077,231 A 4/1937 Fourness et al.

(Continued)

FOREIGN PATENT DOCUMENTS

AU 8774659 1/1988
BE 667613 1/1966

(Continued)

OTHER PUBLICATIONS

Decision of Rejection dated Dec. 4, 2013 from corresponding Japanese Application No. 2009-552722.

(Continued)

(73) Assignee: **Edgewell Personal Care Brands, LLC**, Chesterfield, MO (US)

(*) Notice: Subject to any disclaimer, the term of this patent is extended or adjusted under 35 U.S.C. 154(b) by 13 days.

(21) Appl. No.: **14/576,473**

(22) Filed: **Dec. 19, 2014**

(65) **Prior Publication Data**

US 2015/0105711 A1 Apr. 16, 2015

Related U.S. Application Data

(63) Continuation of application No. 13/669,840, filed on Nov. 6, 2012, now Pat. No. 9,421,135, which is a (Continued)

(51) **Int. Cl.**

A61F 13/20 (2006.01)

A61F 13/26 (2006.01)

A61F 13/34 (2006.01)

(52) **U.S. Cl.**

CPC *A61F 13/266* (2013.01); *A61F 13/26* (2013.01); *A61F 13/2077* (2013.01); (Continued)

(58) **Field of Classification Search**

CPC *A61F 13/26*; *A61F 13/263*; *A61F 13/266*; *A61F 13/34*; *A61F 13/2077* (Continued)

Primary Examiner — Jacqueline Stephens

(74) *Attorney, Agent, or Firm* — Edgewell Personal Care Brands, LLC

(57) **ABSTRACT**

A tampon applicator barrel includes an insertion tip at a forward end of the barrel, a main body section that extends from the insertion tip, and a reverse taper section that is joined to the main body section so that the main body section is between the insertion tip and the reverse taper section. The main body section tapers toward the insertion tip section. The reverse taper section tapers in a direction away from the insertion tip section. A finger grip section extends from the reverse taper section to a plunger receiving end of the barrel opposite the forward end. The barrel is straight from the forward end to the plunger receiving end that receives a plunger.

76 Claims, 2 Drawing Sheets

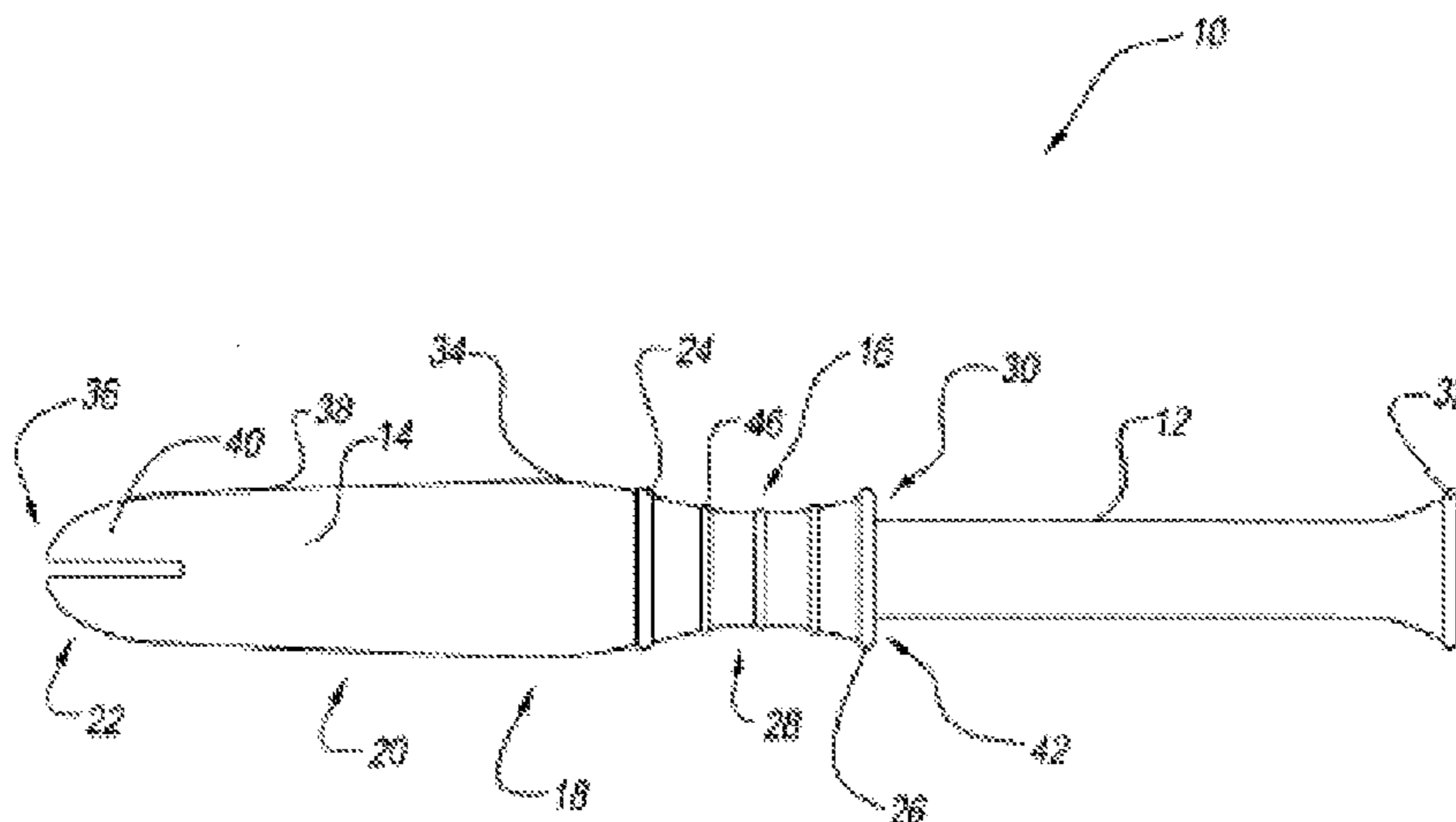

Related U.S. Application Data

continuation of application No. 12/798,990, filed on Apr. 15, 2010, now Pat. No. 8,337,478, which is a continuation of application No. 10/242,474, filed on Sep. 12, 2002, now Pat. No. 7,727,208.

(52) **U.S. Cl.**

CPC *A61F 13/263* (2013.01); *A61F 13/34* (2013.01); *Y10S 604/904* (2013.01)

(58) **Field of Classification Search**

USPC 604/904, 385.17, 385.18, 285, 286, 604/11-18, 311

See application file for complete search history.

(56) **References Cited**

U.S. PATENT DOCUMENTS

2,095,377 A	10/1937	Breese	3,834,389 A	9/1974	Dulle
2,099,931 A	11/1937	Fourness	3,845,767 A	11/1974	Friese et al.
2,123,750 A	7/1938	Schulz	3,856,013 A	12/1974	Dulle
2,178,704 A	11/1939	Robinson	3,858,571 A	1/1975	Rudolph
2,222,088 A	11/1940	Petersen	3,885,563 A	5/1975	Johnson et al.
2,254,272 A	9/1941	Crockford	3,905,372 A	9/1975	Denkinger
2,301,868 A	11/1942	Gurley, Jr. et al.	3,946,737 A	3/1976	Kobler
2,306,406 A	12/1942	Robinson	3,954,104 A	5/1976	Kraskin et al.
2,330,257 A	9/1943	Bailey	3,971,378 A	7/1976	Krantz
2,386,590 A	10/1945	Calhoun	3,981,305 A	9/1976	Ring
2,413,480 A	12/1946	Winter	3,983,873 A	10/1976	Hirschman
2,458,685 A	1/1949	Crockford	3,994,298 A	11/1976	Des Marais
2,476,956 A	7/1949	Bonham	4,010,751 A	3/1977	Ring
2,489,502 A	11/1949	Ruth	4,018,255 A	4/1977	Diggs
2,409,414 A	3/1950	Rabell	4,027,673 A	6/1977	Poncy et al.
2,499,444 A	3/1950	Allison	4,048,998 A	9/1977	Nigro
2,607,346 A	8/1952	Milcent	4,077,408 A	3/1978	Murray et al.
2,706,986 A	4/1955	Carrier	4,077,409 A	3/1978	Murray et al.
2,761,449 A	9/1956	Bletzinger	4,099,976 A	7/1978	Kraskin et al.
2,799,055 A	7/1957	Carrier	4,108,180 A	8/1978	Moehrle
2,854,978 A	10/1958	Millman et al.	D250,663 S	12/1978	Koch et al.
2,877,767 A	3/1959	Schwartz	4,175,457 A	11/1979	Lashley
3,204,635 A	9/1965	Voss et al.	4,185,631 A	1/1980	McConnell
3,264,691 A	8/1966	Whitehead	4,186,742 A	2/1980	Donald
3,291,130 A	12/1966	Whitehead	4,198,978 A	4/1980	Nigro
3,306,294 A	2/1967	Penska	4,211,225 A	7/1980	Sibalis
3,306,295 A	2/1967	Penska	4,212,301 A	7/1980	Johnson
3,347,234 A	10/1967	Voss	4,217,900 A	8/1980	Wiegner et al.
3,358,354 A	12/1967	Voss et al.	4,266,546 A	5/1981	Roland et al.
3,369,544 A	2/1968	Crockford	4,271,835 A	6/1981	Conn et al.
3,397,695 A	8/1968	Voss	4,274,412 A	6/1981	Austin
3,431,909 A	3/1969	Krusko	4,278,088 A	7/1981	Reeves et al.
3,431,910 A	3/1969	Kokx	4,291,696 A	9/1981	Ring
3,433,225 A	3/1969	Voss et al.	4,294,253 A	10/1981	Friese
3,520,302 A	7/1970	Jones	4,308,867 A	1/1982	Roseman et al.
3,570,489 A	3/1971	Brown	4,309,997 A	1/1982	Donald
3,572,341 A	3/1971	Glassman	4,312,348 A	1/1982	Friese
3,575,169 A	4/1971	Voss et al.	4,318,407 A	3/1982	Woon
3,595,236 A	7/1971	Corrigan	4,328,804 A	5/1982	Shimatani
3,606,643 A	9/1971	Mooney	4,335,720 A	6/1982	Glassman
3,628,533 A	12/1971	Loyer	4,335,721 A	6/1982	Matthews
3,643,661 A	2/1972	Crockford	4,341,211 A	7/1982	Kline
3,683,915 A	8/1972	Voss	4,341,214 A	7/1982	Fries et al.
3,690,321 A	9/1972	Hirschman	4,351,339 A	9/1982	Sneider
3,695,270 A	10/1972	Dostal	4,361,150 A	11/1982	Voss
3,699,965 A	10/1972	Dostal	4,361,151 A	11/1982	Fitzgerald
3,706,311 A	12/1972	Kokx et al.	4,373,529 A	2/1983	Lilaonitkul et al.
3,710,793 A	1/1973	Glassman	4,421,504 A	12/1983	Kline
3,712,305 A	1/1973	Wennerblom et al.	4,424,054 A	1/1984	Conn et al.
3,726,277 A	4/1973	Hirschman	4,428,370 A	1/1984	Keely
3,731,687 A	5/1973	Glassman	4,475,911 A	10/1984	Gellert
3,738,364 A	6/1973	Brien et al.	D279,504 S	7/1985	Tump
3,762,413 A	10/1973	Hanke	4,536,178 A	8/1985	Lichstein et al.
3,765,416 A	10/1973	Werner et al.	4,543,086 A	9/1985	Johnson
3,794,029 A	2/1974	Dulle	4,543,098 A	9/1985	Wolfe et al.
3,811,445 A	5/1974	Dostal	4,553,965 A	11/1985	Conn et al.
3,812,856 A	5/1974	Duncan et al.	D287,876 S	1/1987	Blatherwick et al.
			4,676,773 A	6/1987	Sheldon
			4,726,805 A	2/1988	Sanders, III
			4,743,237 A	5/1988	Sweere
			4,755,166 A	7/1988	Olmstead
			4,787,895 A	11/1988	Stokes et al.
			4,845,922 A	7/1989	Sweere
			4,846,802 A	7/1989	Sanders, III
			4,881,644 A	11/1989	Norquest et al.
			4,891,042 A	1/1990	Melvin et al.
			4,973,302 A	11/1990	Armour et al.
			5,004,467 A	4/1991	Hinzmann et al.
			5,019,061 A	5/1991	Hoden et al.
			5,047,024 A	9/1991	Glassman
			5,084,038 A	1/1992	Sheldon et al.
			5,112,348 A	5/1992	Glassman
			5,133,457 A	7/1992	Kadel
			5,149,332 A	9/1992	Walton et al.
			5,153,971 A	10/1992	Van Iten
			5,158,535 A	10/1992	Paul et al.
			5,213,566 A	5/1993	Weissenburger
			5,267,953 A	12/1993	Paul et al.
			5,279,541 A	1/1994	Frayman et al.

(56)

References Cited

U.S. PATENT DOCUMENTS

5,290,501 A	3/1994	Klesius	6,264,626 B1	7/2001	Linares et al.
5,342,331 A	8/1994	Silber et al.	6,270,470 B1	8/2001	Buck et al.
5,350,371 A	9/1994	Van Iten	6,283,952 B1	9/2001	Child et al.
5,364,383 A	11/1994	Hayes et al.	6,299,573 B1	10/2001	Hull, Jr. et al.
5,370,633 A	12/1994	Villalta	6,302,861 B2	10/2001	Tweddell, III et al.
5,387,206 A	2/1995	Valentine et al.	6,302,862 B1	10/2001	Osborn, III et al.
5,389,067 A	2/1995	Rejai	6,310,269 B1	10/2001	Friese et al.
5,395,308 A	3/1995	Fox et al.	6,358,235 B1	3/2002	Osborn, III et al.
5,403,300 A	4/1995	Howarth	6,368,442 B1	4/2002	Linares et al.
5,417,224 A	5/1995	Petrus et al.	6,380,455 B1	4/2002	Moder et al.
5,437,628 A	8/1995	Fox et al.	6,416,488 B1	7/2002	Jackson et al.
5,443,776 A	8/1995	Bartholomew et al.	6,419,777 B1	7/2002	Achter et al.
5,445,605 A	8/1995	Pluss	6,423,025 B1	7/2002	Buzot
5,542,914 A	8/1996	Van Iten	6,432,075 B1	8/2002	Wada et al.
5,547,701 A	8/1996	Nielsen et al.	6,432,076 B1	8/2002	Wada et al.
5,554,108 A	9/1996	Browning et al.	6,432,246 B1	8/2002	Blake
5,584,827 A	12/1996	Korteweg et al.	6,450,986 B1	9/2002	Binner et al.
5,592,725 A	1/1997	Brinker	6,465,713 B1	10/2002	Gell et al.
5,634,248 A	6/1997	McNelis et al.	6,478,764 B1	11/2002	Suga
5,659,934 A	8/1997	Jessup et al.	D467,599 S	12/2002	Brazell
5,681,894 A	10/1997	Williams et al.	6,500,140 B1	12/2002	Cole et al.
5,683,358 A	11/1997	Nielsen et al.	6,506,958 B2	1/2003	Williams
5,693,009 A	12/1997	Fox et al.	6,508,780 B1	1/2003	Edgett et al.
5,718,675 A	2/1998	Leijd	6,511,452 B1	1/2003	Rejai et al.
5,738,646 A	4/1998	Fox et al.	6,545,283 B1	4/2003	Williams et al.
5,755,906 A	5/1998	Achter et al.	6,570,052 B2	5/2003	Zadini et al.
5,766,145 A	6/1998	Fox et al.	6,572,577 B1	6/2003	Binner et al.
5,772,645 A	6/1998	Zadini et al.	D477,075 S	7/2003	Schoelling
5,782,794 A	7/1998	Assenheimer et al.	6,585,300 B1	7/2003	Rajala et al.
5,788,910 A	8/1998	McNelis et al.	6,595,974 B1	7/2003	Pauley et al.
5,792,096 A	8/1998	Rentmeester et al.	6,603,054 B2	8/2003	Chen et al.
5,795,346 A	8/1998	Achter et al.	6,610,025 B2	8/2003	Berg et al.
5,800,338 A	9/1998	Kollerup et al.	6,635,205 B2	10/2003	Williams et al.
5,804,653 A	9/1998	Weng	6,645,136 B1	11/2003	Zunker et al.
5,807,372 A	9/1998	Balzar	6,648,846 B2	11/2003	Binner et al.
5,817,047 A	10/1998	Osborn, III et al.	6,654,992 B2	12/2003	Rajala et al.
5,827,251 A	10/1998	Moder et al.	6,685,787 B2	2/2004	Linares et al.
5,873,971 A	2/1999	Balzar	6,685,788 B2	2/2004	Linares et al.
5,891,081 A	4/1999	McNelis et al.	6,719,743 B1	4/2004	Wada
5,891,123 A	4/1999	Balzar	6,730,057 B2	5/2004	Zhao et al.
5,891,127 A	4/1999	Moder et al.	6,740,070 B2	5/2004	Agyapong et al.
5,911,712 A	6/1999	Leutwyler et al.	D492,033 S	6/2004	Jarmon et al.
5,928,183 A	7/1999	Fox et al.	6,746,418 B1	6/2004	Pauley et al.
5,928,184 A	7/1999	Etheredge et al.	6,756,434 B1	6/2004	Williams et al.
5,931,903 A	9/1999	Jackson	6,773,423 B2	8/2004	Osborn et al.
5,947,992 A	9/1999	Zadini et al.	6,814,722 B2	11/2004	Jackson et al.
5,954,683 A	9/1999	Downs et al.	6,830,554 B2	12/2004	Jackson et al.
5,964,741 A	10/1999	Moder et al.	6,887,226 B2	5/2005	Cassoni et al.
5,986,000 A	11/1999	Williams et al.	6,932,805 B2	8/2005	Domeier et al.
5,986,165 A	11/1999	Moder et al.	6,958,057 B2	10/2005	Berg et al.
6,003,216 A	12/1999	Hull, Jr. et al.	D511,832 S	11/2005	Bellofatto et al.
6,019,743 A	2/2000	Cole et al.	D515,212 S	2/2006	Edgett et al.
6,039,716 A	3/2000	Jessup et al.	7,044,928 B2	5/2006	LeMay et al.
6,039,828 A	3/2000	Achter et al.	7,081,110 B2	7/2006	Karapasha
6,045,526 A	4/2000	Jackson	7,098,292 B2	8/2006	Zhao et al.
6,068,899 A	5/2000	Osborn, III et al.	7,160,279 B2	1/2007	Pauley et al.
6,071,259 A	6/2000	Steiger et al.	7,172,573 B1	2/2007	Lamb et al.
6,090,038 A	7/2000	Zunker et al.	7,226,436 B2	6/2007	Gorham et al.
6,095,998 A	8/2000	Osborn et al.	7,250,129 B2	7/2007	Williams et al.
6,095,999 A	8/2000	Jackson et al.	7,259,129 B2	8/2007	Matusz et al.
6,142,928 A	11/2000	Zunker et al.	7,335,194 B2	2/2008	Wada
6,177,606 B1	1/2001	Etheredge et al.	7,387,622 B1	6/2008	Pauley et al.
6,177,608 B1	1/2001	Weinstrauch	D572,362 S	7/2008	Edgett et al.
6,179,802 B1	1/2001	Jackson	D579,113 S	10/2008	Edgett et al.
6,180,051 B1	1/2001	Schoelling	D612,940 S	3/2010	Edgett et al.
6,183,436 B1	2/2001	Korteweg et al.	7,704,242 B2	4/2010	LeMay et al.
6,186,994 B1	2/2001	Bowles et al.	D626,650 S	11/2010	Edgett et al.
6,190,348 B1	2/2001	Tiemann et al.	D639,864 S	6/2011	Woelfel
6,191,341 B1	2/2001	Shippert	D652,848 S	1/2012	Flanagan et al.
6,196,988 B1	3/2001	Cole et al.	8,198,504 B2	6/2012	Glaug et al.
6,203,515 B1	3/2001	Norquest et al.	8,372,027 B2	2/2013	LeMay et al.
6,206,867 B1	3/2001	Osborn et al.	8,444,590 B2	5/2013	LeMay et al.
6,248,274 B1	6/2001	Williams	8,571,883 B2	10/2013	Dougherty et al.
6,254,565 B1	7/2001	Williams et al.	8,696,957 B2	4/2014	Dougherty et al.
6,254,566 B1	7/2001	Buck et al.	9,107,775 B2	8/2015	Edgett et al.
			2002/0010413 A1	1/2002	Binner et al.
			2002/0010447 A1	1/2002	Williams et al.
			2002/0038109 A1	3/2002	Williams
			2002/0107497 A1	8/2002	Osborn et al.

(56)

References Cited

FOREIGN PATENT DOCUMENTS

U.S. PATENT DOCUMENTS			FOREIGN PATENT DOCUMENTS		
			BE	758152	4/1971
			CA	11086099	9/1980
2002/0133135	A1	9/2002 Gell et al.	CA	1110401	10/1981
2002/0143287	A1	10/2002 Buzot	CA	2024473	3/1991
2002/0143303	A1	10/2002 Intravartolo et al.	CA	2095390	11/1993
2002/0147436	A1	10/2002 Gell et al.	CA	2143083	2/1996
2002/0151859	A1	10/2002 Schoelling	CA	2145692	2/1996
2002/0156442	A1	10/2002 Jackson et al.	CA	2153818	2/1996
2002/0177835	A1	11/2002 Zadini et al.	CA	2280251	2/2000
2002/0183681	A1	12/2002 Bernard	CA	2302065	9/2000
2002/0188264	A1	12/2002 Knuth et al.	CA	2325269	5/2001
2002/0188283	A1	12/2002 Binner et al.	CA	2325669	5/2001
2003/0028176	A1	2/2003 Berg et al.	CA	108982 S	8/2006
2003/0028177	A1	2/2003 Berg et al.	CA	115880 S	8/2008
2003/0036721	A1	2/2003 Zhao et al.	CA	2441647 C	5/2009
2003/0040695	A1	2/2003 Zhao et al.	DE	1920773	12/1969
2003/0055391	A1	3/2003 Nguyen et al.	DE	3328910	2/1985
2003/0073948	A1	4/2003 Binner et al.	DE	3540725	5/1986
2003/0100871	A1	5/2003 Mauro et al.	DE	3726311	2/1989
2003/0105421	A1	6/2003 Jarmon et al.	DE	4446226	6/1995
2003/0125658	A1	7/2003 Marvin	DE	19726648	12/1998
2003/0135180	A1	7/2003 Nguyen et al.	EP	110793	12/1983
2003/0149416	A1	8/2003 Cole et al.	EP	158543	3/1985
2003/0158533	A1	8/2003 Agyapong et al.	EP	0243250	10/1987
2003/0163080	A1	8/2003 LeMay et al.	EP	546256	7/1992
2003/0167048	A1	9/2003 Policappelli	EP	797971	10/1997
2003/0172504	A1	9/2003 Sageser et al.	FR	1515087	3/1968
2003/0176844	A1	9/2003 Randall et al.	FR	2567399	7/1984
2003/0176845	A1	9/2003 Kollwitz et al.	GB	2097259	11/1982
2003/0208179	A1	11/2003 Fuchs et al.	GB	8428462 A	12/1984
2003/0208180	A1	11/2003 Fuchs et al.	GB	9419135	11/1994
2003/0216680	A1	11/2003 Binner et al.	GB	2414394 B	1/2006
2003/0236485	A1	12/2003 Fedyk et al.	GB	2415626 B	3/2006
2004/0000222	A1	1/2004 Rejai	IL	154877	7/2009
2004/0010220	A1	1/2004 Miller et al.	IL	163734	12/2009
2004/0054317	A1	3/2004 LeMay et al.	JP	H05-68695	3/1993
2004/0064082	A1	4/2004 LeMay et al.	JP	10024064	1/1998
2004/0153024	A1	8/2004 Pauley et al.	JP	2000288018	10/2000
2004/0193131	A1	9/2004 Wada	JP	2001-008964	1/2001
2004/0199100	A1	10/2004 LeMay et al.	JP	200117465	1/2001
2004/0199101	A1	10/2004 LeMay et al.	JP	2001145658	5/2001
2004/0199102	A1	10/2004 LeMay et al.	JP	2005-526584	9/2005
2004/0225269	A1	11/2004 Zhao et al.	JP	HO62-027952	9/2005
2004/0243088	A1	12/2004 LeMay et al.	JP	2005531345	10/2005
2005/0015041	A1	1/2005 Karapasha	WO	8000008	1/1980
2005/0020964	A1	1/2005 Melvin et al.	WO	93/08779	5/1993
2005/0022349	A1	2/2005 Pham et al.	WO	94/15564	7/1994
2005/0070839	A1	3/2005 Jackson et al.	WO	9605795	2/1996
2005/0080393	A1	4/2005 Policappelli	WO	9637173	11/1996
2005/0096617	A1	5/2005 Gorham et al.	WO	9640032	12/1996
2005/0096619	A1	5/2005 Costa	WO	9806366	2/1998
2005/0177091	A1	8/2005 Jarmon et al.	WO	9900097	1/1999
2007/0026228	A1	2/2007 Hartmann et al.	WO	0037013	6/2000
2007/0156081	A1	7/2007 Karapasha	WO	0066213	11/2000
2007/0232982	A1	10/2007 Jarmon et al.	WO	0197735	12/2001
2007/0260211	A1	11/2007 Schmidt-Forst	WO	0200153	1/2002
2007/0276317	A1	11/2007 Henderson et al.	WO	0202176	1/2002
2007/0293809	A1	12/2007 Karapasha	WO	0226159	4/2002
2008/0033337	A1	2/2008 Dougherty et al.	WO	02074352	9/2002
2008/0058751	A1	3/2008 Edgett et al.	WO	03032883	4/2003
2008/0119778	A1	5/2008 Jorgensen et al.	WO	03101362 A2	11/2003
2008/0132868	A1	6/2008 Jorgensen et al.	WO	2004000160	12/2003
2008/0167597	A1	7/2008 Dougherty	WO	2004/098449	11/2004
2008/0221502	A1	9/2008 Binner et al.	WO	2005112856 A1	12/2005
2008/0287902	A1	11/2008 Edgett et al.	WO	2005112862 A1	12/2005
2009/0036859	A1	2/2009 Dougherty et al.	WO	2006016933 A1	2/2006
2009/0156979	A1	6/2009 Andersch	WO	2006037157	4/2006
2009/0227975	A1	9/2009 Dougherty et al.	ZA	9305011	2/1994
2009/0234268	A1	9/2009 Jorgensen et al.			
2009/0247981	A1	10/2009 Glaug et al.			
2009/0281474	A1	11/2009 Dougherty et al.			
2009/0281514	A1	11/2009 Dougherty et al.			
2010/0036309	A1	2/2010 Jorgensen et al.			
2010/0120707	A1	5/2010 Dougherty et al.			
2010/0198133	A1	8/2010 Dougherty et al.			
2012/0061867	A1	3/2012 Dougherty et al.			

OTHER PUBLICATIONS

Official Action dated Jan. 22, 2012 from corresponding Mexican Application No. MX/a/2009/009468.
 Decision of Rejection dated Dec. 11, 2012 from corresponding Japanese Application No. 2009-552722.

(56)

References Cited

OTHER PUBLICATIONS

Official Action dated Jan. 22, 2013 from corresponding Mexican Application No. MX/a/2009/009468.

Official Notice of Final Rejection dated Feb. 27, 2012 From Korean Application No. 10-2009-7020746.

Notice of Notice of Reasons for Rejection dated Feb. 20, 2012 from Japanese Application No. 2009-552722. Reasons for Rejection dated Feb. 20, 2012 from Japanese Application No. 2009-552722.

Canadian Office Action dated Apr. 6, 2011 for corresponding Canadian Patent Application No. 2.680.144.

Office Action dated Jun. 14, 2011 from Korean Patent Application No. 10-2009-7020746.

Official Notice dated Aug. 2, 2012 from Korean Application No. 10-2009-7020746.

Notification of the First Office Action dated Apr. 6, 2012 from Chinese Application No. 2008800143883.

Korean Office Action dated Aug. 2, 2012 for corresponding Korean Patent Application No. 10-2009-7020746 with English summary.

European Search Report dated Apr. 27, 2011 for corresponding European Patent Application No. 047606017.

English translation of First Office Action dated Apr. 6, 2012 for corresponding Chinese Patent Application No. 200880143883.

Office Action and English summary of Office Action previously dated Sep. 14, 2012.

Notification of the Second Office Action dated Nov. 30, 2012 from corresponding Chinese Application No. 2008800143883.

Supplementary European Search Report dated Dec. 17, 2012 from corresponding European Application No. 087264628.

Israeli Office Action for corresponding Israeli Patent Application No. 200734 with English summary dated Apr. 5, 2011.

Photocopy of box panels for QB. Silk Ease. Personal Fit Protection.

International Search Report from PCT Application No. PCT/US2008/02934. dated Jul. 14, 2008.

Written Opinion from PCT Application No. PCT/US2008/02934, dated Jul. 14, 2008.

Examination Report dated Aug. 25, 2011 from corresponding European Patent Application No. 04 760 601.7-1217.

"Retrieved from the internet on Mar. 3, 2010: <http://www.inerriamwebstercom'dictionary/slit>."

Canadian Examination Report dated Oct. 7, 2009, from corresponding Application No. 2,498,508.

Canadian Examination Report dated Dec. 18, 2008, from corresponding Application No. 2,498,508.

Canadian Examination Report dated Jan. 15, 2008, from corresponding Application No. 2,498,508.

Canadian Examination Report dated May 3, 2008, from corresponding Application No. 2,498,508.

Notice of Reasons for Rejection dated Aug. 5, 2008, from corresponding Japanese Application No. 2004-536364.

Final Notice of Rejection dated May 12, 2009, from corresponding Japanese Application No. 2004-027399.

Official Action dated Apr. 26, 2005, from corresponding Japanese Application No. 2004-27406.

Notice of Reasons for Rejection dated Oct. 4, 2011, from corresponding Japanese Application No. 2009/209408.

Official Action, from corresponding Mexican Application No. Pa/a/2005/002767.

U.S. Office Action dated Jun. 26, 2007, from corresponding U.S. Appl. No. 29/205,148.

U.S. Office Action dated Jun. 3, 2005, from corresponding U.S. Appl. No. 29/205,148.

U.S. Office Action dated May 16, 2005, from corresponding U.S. Appl. No. 29/201,235.

U.S. Office Action dated Oct. 1, 2007, from corresponding U.S. Appl. No. 29/201,242.

U.S. Office Action dated Aug. 25, 2005, from corresponding U.S. Appl. No. 29/201,242.

U.S. Office Action dated Jul. 2, 2007, from corresponding U.S. Appl. No. 29/201,242.

U.S. Office Action dated Jun. 9, 2009, from corresponding U.S. Appl. No. 10/242,474.

U.S. Office Action dated Dec. 16, 2008, from corresponding U.S. Appl. No. 10/242,474.

U.S. office Action dated May 5, 2008, from corresponding U.S. Appl. No. 10/242,474.

U.S. Office Action dated Dec. 20, 2006, from corresponding U.S. Appl. No. 10/242,474.

U.S. Office Action dated Jun. 16, 2006, from corresponding U.S. Appl. No. 10/242,474.

U.S. Office Action dated May 20, 2004, from corresponding U.S. Appl. No. 10/242,474.

U.S. Office Action dated Jan. 12, 2004, from corresponding U.S. Appl. No. 10/242,474.

U.S. Office Action dated Mar. 10, 2005, from corresponding U.S. Appl. No. 10/242,474.

U.S. Office Action dated Feb. 8, 2005, from corresponding U.S. Appl. No. 10/242,474.

U.S. Office Action dated Nov. 17, 2004, from corresponding U.S. Appl. No. 10/242,474.

U.S. Office Action dated Dec. 30, 2005, from corresponding U.S. Appl. No. 10/242,474.

2005 Gentle Glide Plastic Tampons.

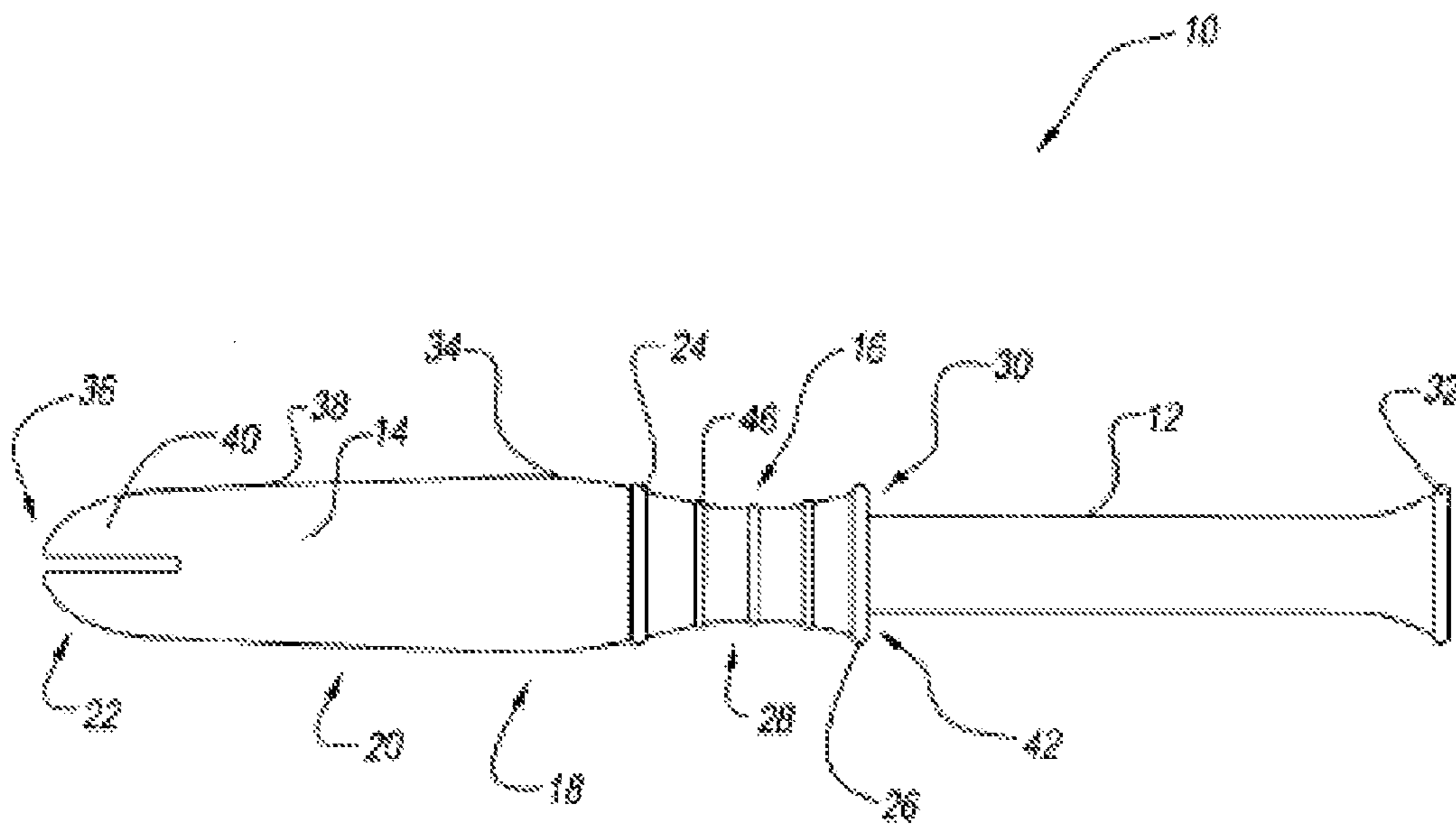

Fig. 1

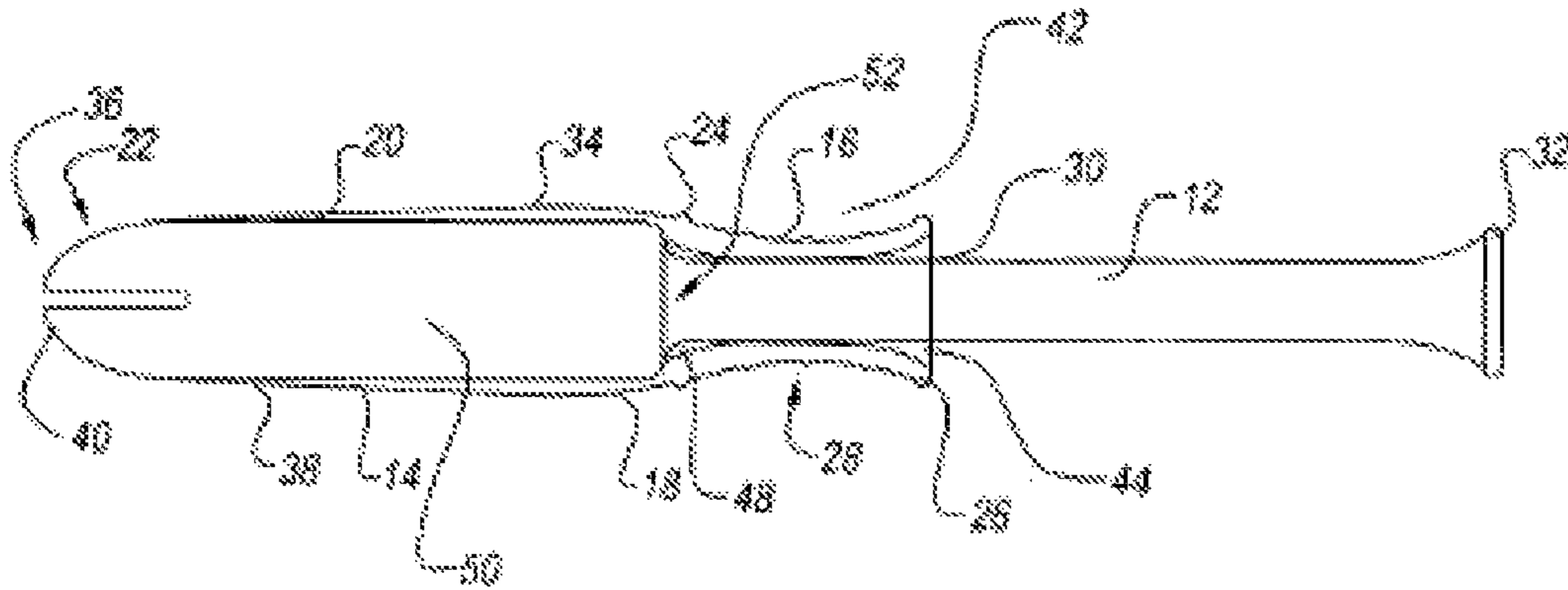

Fig. 2

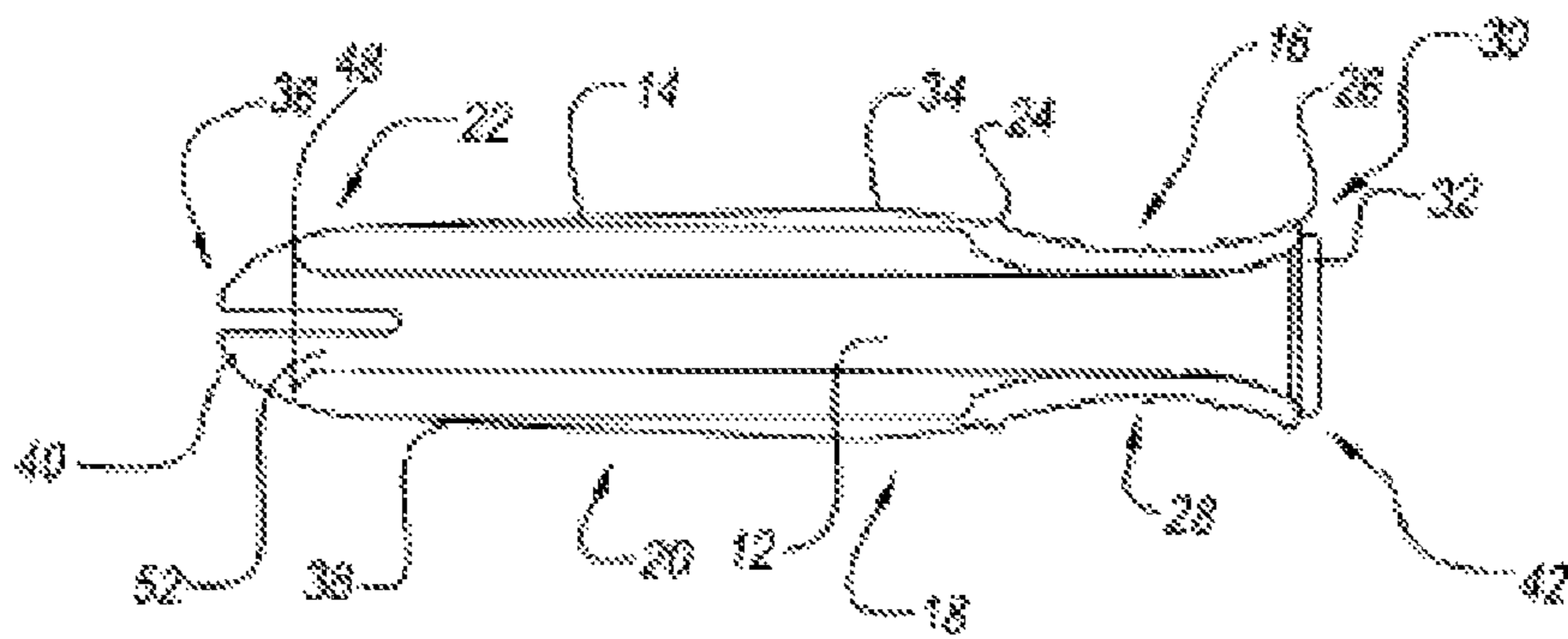

Fig. 3

ERGONOMIC TAMPON APPLICATOR**CROSS-REFERENCE TO RELATED APPLICATIONS**

This is a continuation application of U.S. patent application Ser. No. 13/669,840 filed Nov. 6, 2012, which is a continuation application of U.S. patent application Ser. No. 12/798,990, filed Apr. 15, 2010, which is a continuation application of U.S. patent application Ser. No. 10/242,474, filed Sep. 12, 2002, claims the benefit of priority from U.S. Provisional patent application Ser. No. 60/499,443, filed on 2 Sep. 2003. Each of the above-noted applications is incorporated herein by reference.

BACKGROUND OF THE INVENTION**A. Field of Endeavor**

The disclosure relates generally to an improved tampon or tampon applicator. More particularly, the present disclosure relates to a tampon applicator with a barrel that has a reverse taper section for improved ease of use and user comfort.

B. Description of the Prior Art

Commercial tampon applicators typically consist of a barrel and a plunger used to expel an absorbent pledget housed in the barrel. The barrel is typically sub-divided into three sections, namely a finger grip, an insertion tip, and a main body section, which is located between the finger grip and insertion tip sections.

The finger grip section is typically the same diameter as the main body section of the barrel, but some designs (e.g., Playtex® Gentle Glide®) have a reduced diameter grip for improve grippability. The main body section is typically linear, except on plastic molded barrels where there is a slight taper to improve release characteristics from the manufacturing mold. The insertion tip section on some types of barrels have “petals” which curve over and enclose the pledget (i.e., rounded tip) housed in the barrel, but readily flex outwardly as the pledget is expelled through the insertion tip.

SUMMARY OF THE INVENTION

The present disclosure provides a tampon applicator that is ergonomic.

The present disclosure also provides such an ergonomic tampon applicator with a plunger and a barrel.

The present disclosure further provides such an ergonomic tampon applicator barrel having a finger grip section, a reverse taper section, a main body section and an insertion tip section.

The present disclosure still further provides such an ergonomic tampon applicator barrel reverse taper section where the reverse taper is towards the finger grip section.

The present disclosure also provides such an ergonomic tampon applicator barrel finger grip section having a finger accepting region.

The present disclosure further provides such an ergonomic tampon applicator insertion tip section formed with a plurality of petals.

The present disclosure still further provides such an ergonomic tampon applicator main body section with a maximum diameter section that is sensually perceivable to a user to alert the user to the proper insertion depth of the applicator.

The present disclosure also provides such an ergonomic tampon applicator having a plunger with at least one flared end.

These and other objects and advantages of the present disclosure will be appreciated from an ergonomically improved tampon applicator having a plunger and a barrel, of the present disclosure. The barrel has four distinct sections, namely a finger grip section, a reverse taper section, a main body section, and an insertion tip section. The reverse taper section is tapered towards the fingergrip section, and the main body section is tapered in an opposite direction towards the insertion tip section. A maximum diameter is formed where the reverse taper section and main body section meet on the barrel. The maximum diameter provides a sensory indicator to the user to alert the user when the applicator has been inserted to the proper depth in the vagina.

BRIEF DESCRIPTION OF THE DRAWINGS

FIG. 1 is a plan view of a tampon applicator of the present disclosure;

FIG. 2 is a cut away view of the tampon applicator of FIG. 1 depicting an absorbent pledget housed in the barrel; and

FIG. 3 is a cut away view of the tampon applicator of FIG. 2 after the pledget has been expelled from the barrel.

DETAILED DESCRIPTION OF THE INVENTION

Referring to FIG. 1, drawings and, in particular, FIG. 1, there is shown an ergonomically improved tampon applicator according to the present disclosure generally represented by reference numeral 10. The ergonomically improved applicator 10 is easier to use and more comfortable to insert and remove. Applicator 10 includes a plunger 12 and a barrel 14.

Barrel 14 may be divided into four sections, as opposed to three sections typically found in prior art tampon applicators. The four sections include a finger grip section 16, a reverse taper section 18, a main body section 20, and an insertion tip section 22.

Finger grip section 16 is bound by a forward edge ridge 24 and a rearward edge ridge 26. Forward edge ridge 24 provides a firm grip surface during insertion of applicator 10 into the vaginal vault. Rearward edge ridge 26 provides a firm grip surface during expulsion of the pledget (not shown) and during removal of applicator 10 from the body. Forward and rearward edge ridges 24, 26 are about 6 mm to about 22 mm in diameter. Preferably, the forward and rearward edges 24, 26 are about 11 mm to about 17 mm in diameter, with about 14 mm being the most preferred diameter.

A finger accepting region 28 is formed between forward edge ridge 24 and rearward edge ridge 26. To ensure an adequate area to accept a user's finger or fingers, forward edge ridge 24 and rearward edge ridge 26 are spaced about 13 mm to about 40 mm apart. More preferably, forward edge ridge 24 and rearward edge ridge 26 are spaced about 17 mm to about 21 mm apart, with about 19 mm being the most preferred spacing. Finger accepting region 28 may be concave, convex, flat, or any combinations thereof. Preferably, region 28 is concave, which conforms to the contour of a user's finger. The maximum diameter of region 28 is preferably slightly less than the diameter of edge ridges 24, 26.

Preferably, region **28** has a maximum to minimum diameter ratio of about 1.10 to about 1.75, with a more preferred ratio of about 1.25 to about 1.35.

Finger accepting region **28** may also include one or more gripping structures **46** to improve grippability of applicator **10**. Suitable gripping structures **46** include, for example, one or more and preferably two or more, embossments, protuberances, slits, grooves, louvers, perforations, lances, abrasive medias, high wet coefficient of friction materials, pressure sensitive adhesives, or any combinations thereof. In addition, gripping structures **46** may be formed in any shape, including, for example, arc, circle, concave, cone, convex, diamond, line, oval, polygon, rectangle, rib, square, triangle, or any combinations thereof.

The maximum diameter **34** of applicator barrel **14** occurs at the forward end of reverse taper section **18**. Reverse taper is meant to include a taper in the reverse direction, i.e. in a direction away from the insertion end of applicator **10**, but not necessarily the same dimensional taper as main body section **20**. The diameter of reverse taper section **18** tapers down toward forward edge ridge **24**, where the diameter is equal to or slightly less than the diameter of forward edge ridge **24**. This taper may be linear or curvilinear.

Maximum diameter **34** of barrel **14** exerts a slightly greater pressure than the smaller diameter portions of the barrel on the vaginal opening. This unique feature of barrel **14** provides a sensually perceivable way of signaling or indicating to a user that applicator **10** has been inserted to the correct depth in the vagina. Thus, the location of maximum diameter **34** along the length of barrel **14** is a critical aspect of the present disclosure. The location of maximum diameter **34** on barrel **14** is about 32 mm to about 54 mm in the axial direction of barrel **14** from forward end **36** of insertion tip **22**. Preferably maximum diameter **34** is located about 40 mm to about 50 mm, and more preferably about 44 mm in the axial direction of barrel **14** from forward end **36** of insertion tip **22**.

Main body section **20** is joined to reverse taper section **18** where maximum diameter **34** of barrel **14** is located. Main body section **20** tapers toward insertion tip section **22** in either a linear or curvilinear fashion so that its smallest diameter occurs where main body section **20** meets insertion tip section **22**. The ratio of maximum diameter **34** to the diameter at the forward end **38** of main body section **20** is about 1.1 to about 1.5, and more preferably about 1.2 to about 1.3. This tapering of main body section **20** facilitates insertion comfort by gradually parting the vulva-vaginal channel over a longer length than that of only insertion tip section **22**.

Insertion tip section **22** begins where there is a substantial change in the curvature of the forward portion of the barrel that is where the pledget-enclosing petals **40** are formed. In applicator designs where no petals are used, insertion tip **22** is the forward edge of the main body section **20** of barrel **14**. The preferred insertion tip **22** is the petal type with a curvature that approximates an elliptical or hyperbolic curve. Preferably, insertion tip **22** has about 2 to about 12 petals, and more preferably about 3 to about 8 petals. The ratio of the maximum diameter of insertion tip section **22**, which occurs at the plane where its rearward edge meets forward end **38** of main body section **20**, to the total axial length of the insertion tip section along a horizontal axis of applicator **10**, is about 0.9 to about 1.8, and more preferably about 1.1 to about 1.3.

The less severe curvature of insertion tip section **22** also facilitates insertion comfort by gradually parting the vulva-vaginal channel along its longer length.

It should be understood that while tampon applicator barrel **14** of the present disclosure is depicted as having four sections, namely a finger grip section, a reverse taper section, a main body section, and an insertion tip section, the tampon applicator barrel can include a reverse taper section and at least one additional section selected from a finger grip section, a main body section, an insertion tip section, or any combinations thereof.

The interior wall of barrel **14** that houses the pledget may have the same basic sidewall shape as its exterior wall. However, molding such a complicated interior wall requires a complex manufacturing process. Alternately, the interior wall can be practically straight walled (a slight taper may be required for tooling release) while the exterior wall has the sectional shapes discussed before, thus simplifying the molding process.

Referring to FIGS. **2** and **3**, barrel **14** has a finger grip end **42**. Plunger **12** telescopically fits into the finger grip end **42** of barrel **14**. Plunger **12** has a diameter slightly smaller than the smallest diameter of finger receiving region **28** so that plunger **12** telescopically fits throughout the interior of barrel **14**. Preferably, in one embodiment of the present disclosure, plunger **12** has a diameter about 4 mm to about 18 mm. More preferably, plunger **12** has a diameter about 5 mm to about 9 mm with the most preferred diameter being about 7 mm.

Plunger **12** has a first flare **32** at its distal end and a second flare or retaining structure **48** at its opposite barrel end **52**. Finger grip section **16** has a plunger receiving end **30**. Plunger receiving end **30** of finger grip section **16** has a chamfer **44** to receive first flare **32** of plunger **12** during pledget expulsion. This permits shortening the length of the section of plunger **12** that protrudes from barrel **14** since all of the protruded length is available for the telescopic action. This in turns results in a more ergonomic applicator. Such an ergonomic applicator is conducive to one handed use, since the distance between finger grip section **16** and first flare **32**, where the fingertip is placed, is reduced by an amount equal to the length of first flare **32**. Second flare or retaining feature **48** on barrel end **52** of plunger **12** prevents separation from barrel **14**.

First flare **32** has a maximum diameter about 6 mm to about 22 mm. Preferably the maximum diameter is about 12 mm to about 16 mm, with about 13 mm being the most preferred maximum diameter, in order to provide a secure area for a user's fingertip during pledget expulsion. The rearward end of first flare **32** may be flat, concave, or convex. Preferably, it is concave to provide a secure area for the fingertip.

Second flare **48** has a maximum diameter about 5 mm to about 20 mm. Preferably the maximum diameter is about 11 mm to about 14 mm, with about 13 mm being the most preferred maximum diameter, in order to prevent separation from barrel **14**.

Although it might be implied that the cross-sectional shape of plunger **12** and barrel **14** is circular, due to the use of the term 'diameter', it should be understood that the cross-sectional shape can be non-circular, such as oval or polygonal. Furthermore, the cross-sectional shape can vary along the length of both plunger **12** and barrel **14**. For example, a circular plunger with a polygonal finger grip and an oval main body may be formed.

The pledget housed by applicator barrel **14** preferably has a tapered forward end that corresponds to that of insertion tip **22**. The matching taper supports petals **40** during insertion of applicator **10** so that the petals cannot flex out of shape, thus enhancing comfort. Additionally, during expulsion from

5

applicator 10, the pledget's tapered tip will gradually part the vaginal channel, further enhancing user comfort.

Suitable materials for forming plunger 12 and/or barrel 14 include, for example, biopolymer, cardboard, heat shrink plastic, paper slurry, plastic, plastic tubing, pulp slurry, 5 pulp-molded paper, or any combinations thereof.

To reduce friction and/or increase strength, plunger 12 and/or barrel 14 may be coated with a coating material. Suitable coating materials include, for example, cellophane, cellulose, epoxy, lacquer, nitrocellulose, nylon, plastic, poly- 10 ester, polylactide, polyolefin, polyvinyl alcohol, polyvinyl chloride, silicone, wax, or any combinations thereof.

The foregoing specification and drawings are merely illustrative of the present invention and are not intended to limit the invention to the disclosed embodiments. Variations 15 and changes, which are obvious to one skilled in the art, are intended to be within the scope and nature of the present invention, which is defined in the appended claims.

The invention claimed is:

1. A tampon applicator, comprising: 20
 - an insertion tip section having between three and eight petals;
 - a main body section adjacent said insertion tip section, said main body section having a maximum diameter of said tampon applicator; 25
 - a reverse taper section adjacent said main body section, wherein said reverse taper section tapers downwardly in a direction away from said insertion tip section; and
 - a finger grip section having a forward end adjacent said reverse taper section, said finger grip section having a flared rearward end opposite said forward end defining an opening, wherein said finger grip section has at least one gripping structure, said finger grip section having a generally circular cross-sectional shape, 30
 - wherein said finger grip section has a minimum diameter that is less than said maximum diameter of said main body section, 35
 - wherein said flared rearward end has a rearward end diameter greater than said minimum diameter in said finger grip section, 40
 - wherein said flared rearward end diameter is less than said maximum diameter of said main body section,
 - wherein said at least one gripping structure has a grip structure diameter that is less than said flared rearward end diameter, 45
 - wherein said tampon applicator has a straight central axis, and said insertion tip section, said main body section, said reverse taper section, and said finger grip section are all coaxially positioned around said central axis of said applicator, 50
 - wherein said petals have a curved shape that taper towards said central axis.
2. The tampon applicator of claim 1, wherein said at least one gripping structure is a protuberance.
3. The tampon applicator of claim 1, wherein said at least one gripping structure is a rib. 55
4. The tampon applicator of claim 1, wherein said at least one gripping structure is a groove.
5. The tampon applicator of claim 1, wherein said at least one gripping structure has a coefficient of friction that is greater than a coefficient of friction of said main body section or said reverse taper section. 60
6. The tampon applicator of claim 1, wherein said finger grip section is concave.
7. The tampon applicator assembly according to claim 1, wherein said insertion tip section has said curved shape along said straight central axis that at least partially approxi-

6

mates at least one of an elliptical curved tapered shape and a hyperbolic curved tapered shape.

8. The tampon applicator according to claim 1, wherein said insertion tip section has a ratio of a maximum diameter of said insertion tip section to a length of said insertion tip section that is about 1.1 to about 1.3.

9. A tampon applicator assembly, comprising:
 - a plastic applicator barrel having an internal cavity and a straight central axis, comprising:
 - an insertion tip section having a generally curved tapered shape along said straight central axis, said insertion tip section having between three and eight petals;
 - a main body section adjacent said insertion tip section, said main body section having a maximum diameter of said applicator barrel;
 - a reverse taper section adjacent said main body section, wherein said reverse taper section tapers downwardly in a direction away from said insertion tip section; and
 - a finger grip section having a forward end adjacent said reverse taper section, said finger grip section having a rearward end opposite said forward end said rearward end of said finger grip section defining an opening, said finger grip section having a generally concave shape between said forward end and said rearward end, said finger grip section including a plurality of gripping structures extending outward from an outer surface of said finger grip section between said forward end and said rearward end, said finger grip section having an external minimum grip diameter located between said forward end and said rearward end, said external minimum grip diameter is less than said maximum diameter of said applicator barrel in said main body section, said finger grip section having an internal minimum grip diameter; and
 - a plunger that telescopically fits through said opening in said rearward end of said finger grip section, said plunger having a flared front end, a generally cylindrical middle region, and a flared rear end opposite said flared front end, said plunger having an external middle plunger diameter in said generally cylindrical middle region that is slightly smaller than said internal minimum grip diameter of said finger grip section, 40
 - wherein said insertion tip section, said main body section, said reverse taper section and said finger grip section are all coaxially positioned around said straight central axis of said applicator barrel and are unitary such that said applicator barrel is a unitary plastic piece, 45
 - wherein said applicator barrel includes a transition region in which a smaller wall thickness within said main body section as it transitions to a larger wall thickness in said reverse taper section and said finger grip section, said flared front end of said plunger engaging an internal wall within said transition region to retain said flared front end of said plunger in said applicator barrel.
10. The tampon applicator assembly of claim 9, wherein said external minimum grip diameter of said finger grip section is less than a grip structure diameter of said plurality of gripping structures.
11. The tampon applicator assembly according to claim 10, wherein said grip structure diameter of said plurality of gripping structures is less than said maximum diameter of said applicator barrel. 65

12. The tampon applicator assembly according to claim 11, wherein said plurality of gripping structures encircle said outer surface of said finger grip section.

13. The tampon applicator assembly of claim 9, wherein said generally concave shape of said finger grip section results in a ratio of a maximum external diameter of said finger grip section to said external minimum grip diameter of said finger grip section of about 1.1 to about 1.75.

14. The tampon applicator assembly according to claim 13, wherein said finger grip section has a ratio of said maximum external diameter of said finger grip section to said external minimum grip diameter of said finger grip section of about 1.25 to about 1.35.

15. The tampon applicator assembly according to claim 9, wherein said petals are discrete and separated from each other by a plurality of slits that form a break of material through a tubular wall of said applicator barrel.

16. The tampon applicator assembly according to claim 9, wherein said insertion tip section has said curved tapered shape along said central axis that at least partially approximates at least one of an elliptical curved tapered shape and a hyperbolic curved tapered shape.

17. The tampon applicator assembly according to claim 9, wherein said flared rear end of said plunger has a rear plunger diameter of about 6 mm to about 22 mm.

18. The tampon applicator assembly according to claim 17, wherein said flared rear end of said plunger has said rear plunger diameter of about 12 mm to about 16 mm.

19. The tampon applicator assembly according to claim 18, wherein said flared rear end of said plunger has said rear plunger diameter of about 12 mm.

20. The tampon applicator assembly according to claim 9, wherein said insertion tip section has a ratio of a maximum diameter of said insertion tip section to a length of said insertion tip section that is about 1.1 to about 1.3.

21. The tampon applicator assembly according to claim 9, wherein said insertion tip section has a tip end and a main body section end opposite said tip end, said main body section end adjacent said main body section, wherein said maximum diameter of said applicator barrel is between about 32 mm and about 54 mm from said tip end of said insertion tip section.

22. The tampon applicator assembly according to claim 9, wherein said maximum diameter of said applicator barrel is adjacent said reverse taper section.

23. The tampon applicator assembly according to claim 9, wherein said reverse taper section has a reverse taper diameter that is slightly less than a forward end grip diameter of said forward end of said finger grip section.

24. The tampon applicator assembly according to claim 9, wherein said generally concave shape of said finger grip section comprises one or more flat portions.

25. The tampon applicator assembly according to claim 9, wherein said plurality of gripping structures comprises a plurality of ribs sequentially positioned along a length of said finger grip section.

26. The tampon applicator assembly according to claim 25, wherein said plurality of ribs are sequentially positioned along the entirety of said length of said finger grip section.

27. The tampon applicator assembly according to claim 9, wherein said forward end of said finger grip section has a forward edge and said rearward end of said finger grip section has a rearward edge.

28. The tampon applicator assembly according to claim 9, wherein said forward end of said finger grip section has a forward end grip diameter and said rearward end of said finger grip section has a rearward end grip diameter, wherein

said forward end grip diameter and said rearward end grip diameter are about 11 mm to about 17 mm.

29. The tampon applicator assembly according to claim 9, wherein said forward end and said rearward end are spaced about 17 mm to about 21 mm apart.

30. The tampon applicator assembly according to claim 9, wherein a retaining structure comprises said flared front end of said plunger, wherein said flared front end of said plunger has a front plunger diameter of about 5 mm to about 20 mm.

31. The tampon applicator assembly according to claim 30, wherein said flared front end has said front plunger diameter of about 11 mm to about 14 mm.

32. The tampon applicator assembly according to claim 9, wherein said external middle plunger diameter of said middle region of said plunger is about 4 mm to about 18 mm.

33. The tampon applicator assembly according to claim 32 wherein said external middle plunger diameter of said middle region of said plunger is about 5 mm to about 9 mm.

34. A tampon assembly, comprising, comprising:

a plastic applicator barrel having an internal cavity and a straight central axis, said applicator barrel including:

an insertion tip section having between three and eight petals, said insertion tip section having a curved tapered shape along said central axis said insertion tip section having a front tip opposite a back end;

a main body section adjacent said back end of said insertion tip section, said main body section having a maximum diameter of said applicator barrel; said main body section having a main body section maximum wall thickness;

a reverse taper section adjacent said main body section, wherein said reverse taper section tapers downwardly in a direction away from said insertion tip section; and

a finger grip section adjacent said reverse taper section, said finger grip section having a forward edge adjacent said reverse taper section, said finger grip section having a rearward edge opposite said forward edge, said rearward edge defining an opening, said finger grip section having an external minimum grip diameter that is less than said maximum diameter of said applicator barrel, said finger grip section having an internal minimum grip diameter, said finger grip section having a circular cross-sectional shape and having a finger grip section maximum wall thickness that is greater than said main body section maximum wall thickness,

a plunger that fits through said opening in said rearward edge, said plunger having a flared front end, a generally cylindrical middle region, and a flared rear end, said flared rear end having a rear plunger diameter that is smaller than said rearward edge of said finger grip section, said flared front end having a front plunger diameter that is larger than said internal minimum grip diameter, said plunger having an external middle plunger diameter that is slightly smaller than said internal minimum grip diameter of said finger grip section, said plunger to be pushed forwardly toward said internal cavity along said straight central axis; and a pledget within said internal cavity of said applicator barrel, said pledget including a tapered forward end; wherein said insertion tip section, said main body section, said reverse taper section, and said finger grip section are all coaxially positioned around said central axis of said applicator barrel such that said applicator barrel is unitary.

35. The tampon assembly according to claim 34, wherein said insertion tip section has a ratio of a maximum diameter of said insertion tip section to a length of said insertion tip section that is about 1.1 to about 1.3.

36. The tampon assembly according to claim 34, wherein said insertion tip section has said curved tapered shaped along said straight central axis that at least partially approximates at least one of an elliptical curved tapered shape and a hyperbolic curved tapered shape.

37. The tampon assembly according to claim 34, wherein said pledget has said tapered forward end that corresponds to said insertion tip section.

38. The tampon assembly according to claim 34, wherein said maximum diameter of said applicator barrel is between about 32 mm and about 54 mm from said front tip of the insertion tip section.

39. The tampon assembly according to claim 34, wherein said maximum diameter of said applicator barrel is adjacent said reverse taper section.

40. The tampon assembly according to claim 34, wherein said reverse taper section is between about 50 mm and about 54 mm from said front tip of said insertion tip section.

41. The tampon assembly according to claim 34, wherein said reverse taper section has a reverse taper diameter that is less than said maximum diameter of said applicator barrel.

42. The tampon assembly according to claim 34, wherein said finger grip section is concave, flat, and combinations thereof.

43. The tampon assembly according to claim 34, wherein a distance between said forward edge of said finger grip section and said rearward edge of said finger grip section is between about 13 mm and about 40 mm.

44. The tampon assembly of claim 34, wherein said finger grip section further comprises at least one gripping structure.

45. The tampon assembly of claim 44, wherein said finger grip section has a minimum diameter less than a gripping structure diameter.

46. The tampon assembly according to claim 45, wherein said gripping structure diameter is less than said maximum diameter of said applicator barrel.

47. The tampon assembly according to claim 44, wherein said rearward edge of said finger grip section is flared and has a rearward grip diameter of said finger grip section that is greater than said external minimum grip diameter of said finger grip section.

48. The tampon assembly according to claim 47, wherein said rearward grip diameter of said finger grip section is less than said maximum diameter of said applicator barrel.

49. The tampon assembly according to claim 47, wherein said rearward grip diameter of said finger grip section is greater than a gripping structure diameter of said at least one gripping structure.

50. The tampon assembly according to claim 47, wherein said forward edge has a forward grip diameter and said rearward grip diameter are about 11 mm to about 17 mm.

51. The tampon assembly according to claim 44, wherein said at least one gripping structure encircles an outer surface of said finger grip section.

52. The tampon assembly according to claim 34, wherein a grip edge distance between said forward edge and said rearward edge is about 17 mm to about 21 mm.

53. The tampon assembly according to claim 34, wherein said finger grip section has a maximum to minimum diameter ratio of about 1.1 to about 1.75.

54. The tampon assembly according to claim 53, wherein said finger grip section has said maximum to minimum diameter ratio of about 1.25 to about 1.35.

55. The tampon assembly according to claim 34, wherein said external middle plunger diameter of said plunger is about 7 mm.

56. The tampon assembly according to claim 34, wherein said rear plunger diameter of said plunger is between about 12 mm and about 16 mm.

57. The tampon assembly according to claim 56, wherein said rear plunger diameter of said plunger is about 12 mm.

58. The tampon assembly according to claim 34, wherein said flared front end of said plunger engages an internal wall of said finger grip section such that said flared front end of said plunger is retained within said applicator barrel.

59. The tampon assembly according to claim 58, wherein said internal wall of said finger grip section is proximal said forward edge of said finger grip section.

60. The tampon assembly according to claim 34 or 59, wherein said forward edge corresponds to said finger grip section maximum wall thickness.

61. The tampon assembly according to claim 34, wherein said reverse taper section has a reverse taper section maximum wall thickness greater than said main body section maximum wall thickness.

62. The tampon assembly according to claim 61, wherein said reverse taper section maximum wall thickness is adjacent said finger grip section maximum wall thickness.

63. A tampon assembly, comprising:
 a plastic applicator barrel having an internal cavity and a straight central axis, said applicator barrel including:
 an insertion tip section having a generally curved tapered shape along said straight central axis, said insertion tip having between three and eight petals;
 a main body section adjacent said insertion tip section, said main body section having a maximum diameter of said applicator barrel;
 a reverse taper section adjacent to said main body section, said reverse taper section tapering downwardly in a direction away from said insertion tip section;
 a finger grip section adjacent to said reverse taper section and being bound by a forward edge and a flared rearward edge, said reverse taper section tapering downwardly toward said forward edge, said finger grip section including a plurality of gripping structures extending away from a surface of said finger grip section between said forward edge and said rearward edge, each of said plurality of gripping structures extending around said finger grip section and having a maximum grip structure diameter that is less than a forward grip diameter of said forward edge and a rearward grip diameter of said flared rearward edge, said finger grip section including an opening leading into said internal cavity; and
 wherein said insertion tip section, said main body section, said reverse taper section and said finger grip section are coaxially positioned around said straight central axis of said applicator barrel and are unitary such that said applicator barrel is a unitary plastic piece, said applicator barrel including a transition region in which a smaller wall thickness in said main body section transitions to a larger wall thicknesses in said reverse taper section and said finger grip section;
 a pledget within said internal cavity of said applicator barrel, said pledget including a tapered forward end; and
 a plunger that extends into said internal cavity of said applicator barrel through said opening in said finger

11

grip section, said plunger having a flared front end, a generally cylindrical middle region, and a flared rear end, said flared rear end having a rear plunger diameter that is smaller than said rearward grip diameter of said rearward edge of said finger grip section, said flared front end having a front plunger diameter that is larger than an internal wall diameter within said transition region of said applicator barrel such that said plunger is retained within said applicator barrel.

64. The tampon assembly according to claim 63, wherein said insertion tip section has a ratio of a maximum diameter of said insertion tip to a length of said insertion tip that is about 1.1 to about 1.3.

65. The tampon assembly according to claim 63, wherein said insertion tip section has said curved tapered shape along said straight central axis that at least partially approximates at least one of an elliptical curved tapered shape and a hyperbolic curved tapered shape.

66. The tampon assembly according to claim 63, wherein said pledget has said tapered forward end that corresponds to said insertion tip section.

67. The tampon assembly according to claim 63, wherein said flared front end of said plunger is received within said petals of said insertion tip section as said plunger expels said pledget through said petals.

68. The tampon assembly according to claim 63, wherein said flared front end of said plunger extends beyond 50% of a length of said petals as said plunger expels said pledget through said petals.

12

69. The tampon assembly according to claim 63, wherein said insertion tip section has a thinnest wall thickness that is less than said smaller wall thickness of said main body section.

70. The tampon assembly according to claim 63, wherein an internal wall of said applicator barrel within said finger grip section includes a flared forward internal surface and a flared rearward internal surface.

71. The tampon assembly according to claim 70, wherein said internal wall of said applicator barrel within said finger grip section includes a generally cylindrical surface between said flared forward internal surface and said flared rearward internal surface.

72. The tampon assembly according to claim 70, wherein said flared rearward internal surface within said finger grip section is for engaging said flared rear end of said plunger as said plunger expels said pledget through said petals.

73. The tampon assembly according to claim 70, wherein said flared front end of said plunger engages said internal wall of said applicator barrel such that said flared front end of said plunger is retained within said applicator barrel.

74. The tampon assembly according to claim 70, wherein said flared forward internal surface corresponds to a finger grip section maximum wall thickness.

75. The tampon assembly according to claim 74, wherein said reverse taper section has a reverse taper section maximum wall thickness greater than said smaller wall thickness in said main body section.

76. The tampon assembly according to claim 75, wherein said reverse taper section maximum wall thickness is adjacent said finger grip section maximum wall thickness.

* * * * *