

US010446986B2

(12) **United States Patent**
Zhong et al.

(10) **Patent No.:** **US 10,446,986 B2**
(45) **Date of Patent:** **Oct. 15, 2019**

(54) **ELECTRICAL CONNECTOR WITH
ADDITIONAL SHIELDING**

(71) Applicants: **FOXCONN (KUNSHAN)
COMPUTER CONNECTOR CO.,
LTD.**, Kunshan (CN); **FOXCONN
INTERCONNECT TECHNOLOGY
LIMITED**, Grand Cayman (KY)

(72) Inventors: **Wei Zhong**, Kunshan (CN);
Jian-Kuang Zhu, Kunshan (CN)

(73) Assignees: **FOXCONN (KUNSHAN)
COMPUTER CONNECTOR CO.,
LTD.**, Kunshan (CN); **FOXCONN
INTERCONNECT TECHNOLOGY
LIMITED**, Grand Cayman (KY)

(*) Notice: Subject to any disclaimer, the term of this
patent is extended or adjusted under 35
U.S.C. 154(b) by 0 days.

(21) Appl. No.: **16/228,659**

(22) Filed: **Dec. 20, 2018**

(65) **Prior Publication Data**
US 2019/0190210 A1 Jun. 20, 2019

(30) **Foreign Application Priority Data**
Dec. 20, 2017 (CN) 2017 1 1383071

(51) **Int. Cl.**
H01R 13/6585 (2011.01)
H01R 13/405 (2006.01)
(Continued)

(52) **U.S. Cl.**
CPC **H01R 13/6585** (2013.01); **H01R 13/405**
(2013.01); **H01R 13/6582** (2013.01);
(Continued)

(58) **Field of Classification Search**
CPC H01R 13/6585; H01R 13/6582; H01R
13/6596; H01R 13/405; H01R 43/02
See application file for complete search history.

(56) **References Cited**

U.S. PATENT DOCUMENTS

7,261,598 B1 * 8/2007 Tseng H01R 13/6582
439/607.36
7,601,029 B2 * 10/2009 Horiuchi H01R 4/20
439/497

(Continued)

FOREIGN PATENT DOCUMENTS

CN 201562838 U 8/2010
CN 104425995 B 1/2017

(Continued)

Primary Examiner — Brigitte R. Hammond
(74) *Attorney, Agent, or Firm* — Wei Te Chung; Ming
Chieh Chang

(57) **ABSTRACT**

A electrical connector includes an insulative elongated hous-
ing and first and second metallic shells covering the housing.
The housing includes a top surface, a bottom surface, two
sides surfaces and a middle surface between the top surface
and the bottom surface so as to form a step structure thereof.
The primary shell covers the top surface, the bottom surface
and two side surfaces, and the secondary shell covers the
middle surface and the rear surface which is roughly joined
with the middle surface, and further the primary shell on the
bottom surface in an overlapped manner so as to avoid any
electrical leaking along the front-to-back direction between
the primary shell and the secondary shell.

15 Claims, 12 Drawing Sheets

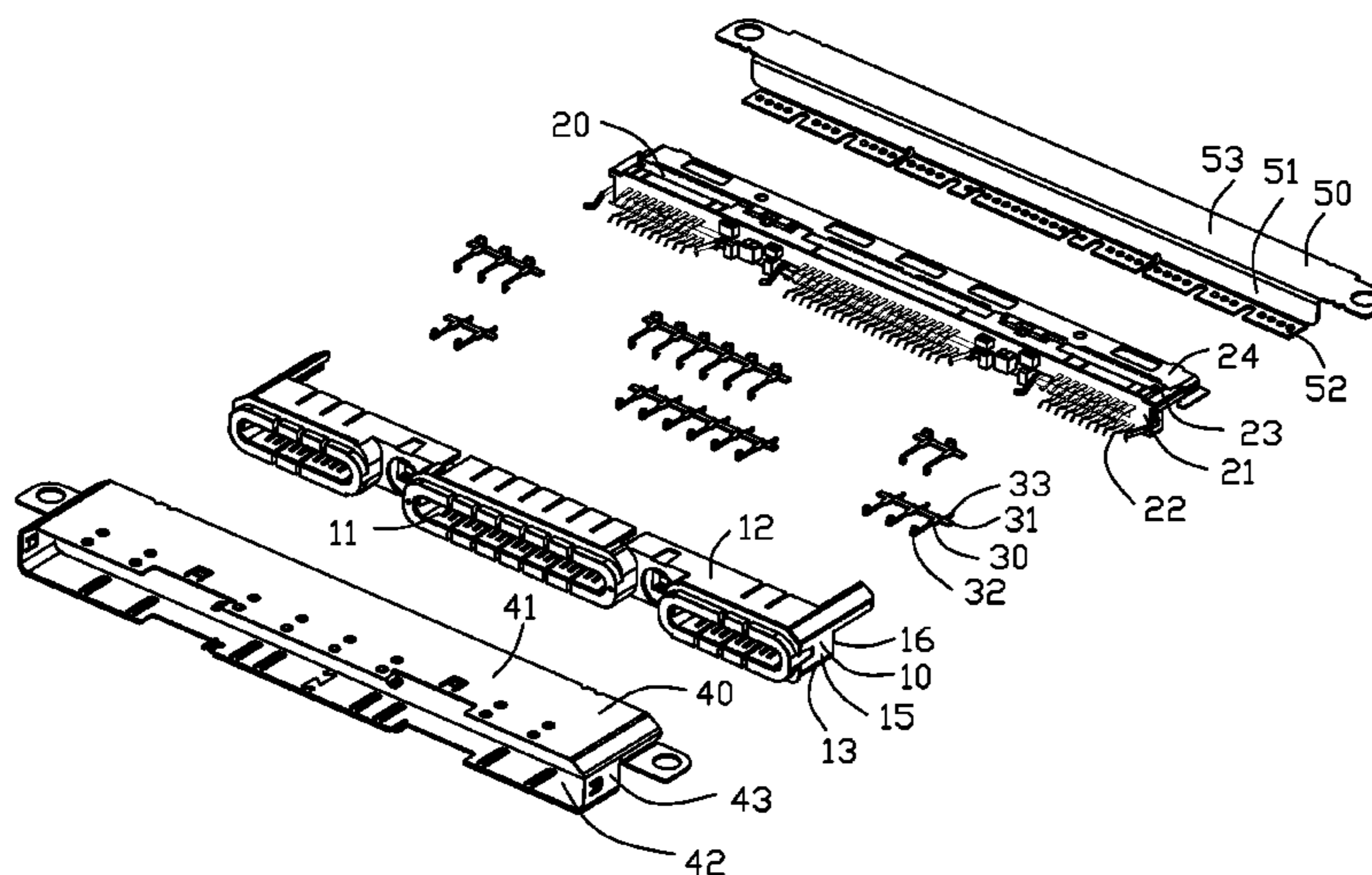

- | | | | | |
|------------------------------|---|---|--|--|
| (51) Int. Cl. | <i>H01R 13/6596</i> (2011.01)
<i>H01R 13/6582</i> (2011.01)
<i>H01R 43/02</i> (2006.01)
<i>H01R 43/24</i> (2006.01)
<i>H01R 13/6593</i> (2011.01) | 8,241,065 B2 * 8/2012 Ikari H01R 12/775
439/372
8,287,311 B2 * 10/2012 Lin H01R 9/05
439/607.55
8,337,249 B2 * 12/2012 Lappoehn H01R 13/6585
439/607.55
8,597,051 B2 * 12/2013 Yang H01R 12/57
439/589 | | |
| (52) U.S. Cl. | CPC <i>H01R 13/6593</i> (2013.01); <i>H01R 13/6596</i>
(2013.01); <i>H01R 43/02</i> (2013.01); <i>H01R</i>
<i>43/24</i> (2013.01) | 8,740,649 B2 * 6/2014 Lan H01R 13/506
439/607.4
9,208,922 B2 * 12/2015 Yoshida H01B 1/02
9,647,395 B2 * 5/2017 Hsu H01R 13/405
9,780,468 B2 * 10/2017 Yokoyama H01R 12/7047
10,128,618 B1 * 11/2018 Briant H01R 13/6581
10,153,594 B2 * 12/2018 Wu H01R 12/775
10,297,955 B2 * 5/2019 Zhu H01R 13/6581
2003/0176111 A1 * 9/2003 Iida H01R 12/592
439/660
2009/0029601 A1 * 1/2009 Yamaji H01R 12/592
439/694 | | |
| (56) References Cited | U.S. PATENT DOCUMENTS

7,699,655 B2 * 4/2010 Wang H01R 12/57
439/607.33
7,736,172 B2 * 6/2010 Yang H01R 13/6275
439/358
7,794,271 B2 * 9/2010 Wu H01R 12/598
439/497
7,914,322 B2 * 3/2011 Lin H01R 4/023
439/497
8,172,616 B2 * 5/2012 Miyazaki H01R 12/592
439/607.55 | FOREIGN PATENT DOCUMENTS

CN 106410517 A 2/2017
CN 206004086 U 3/2017 | | |

* cited by examiner

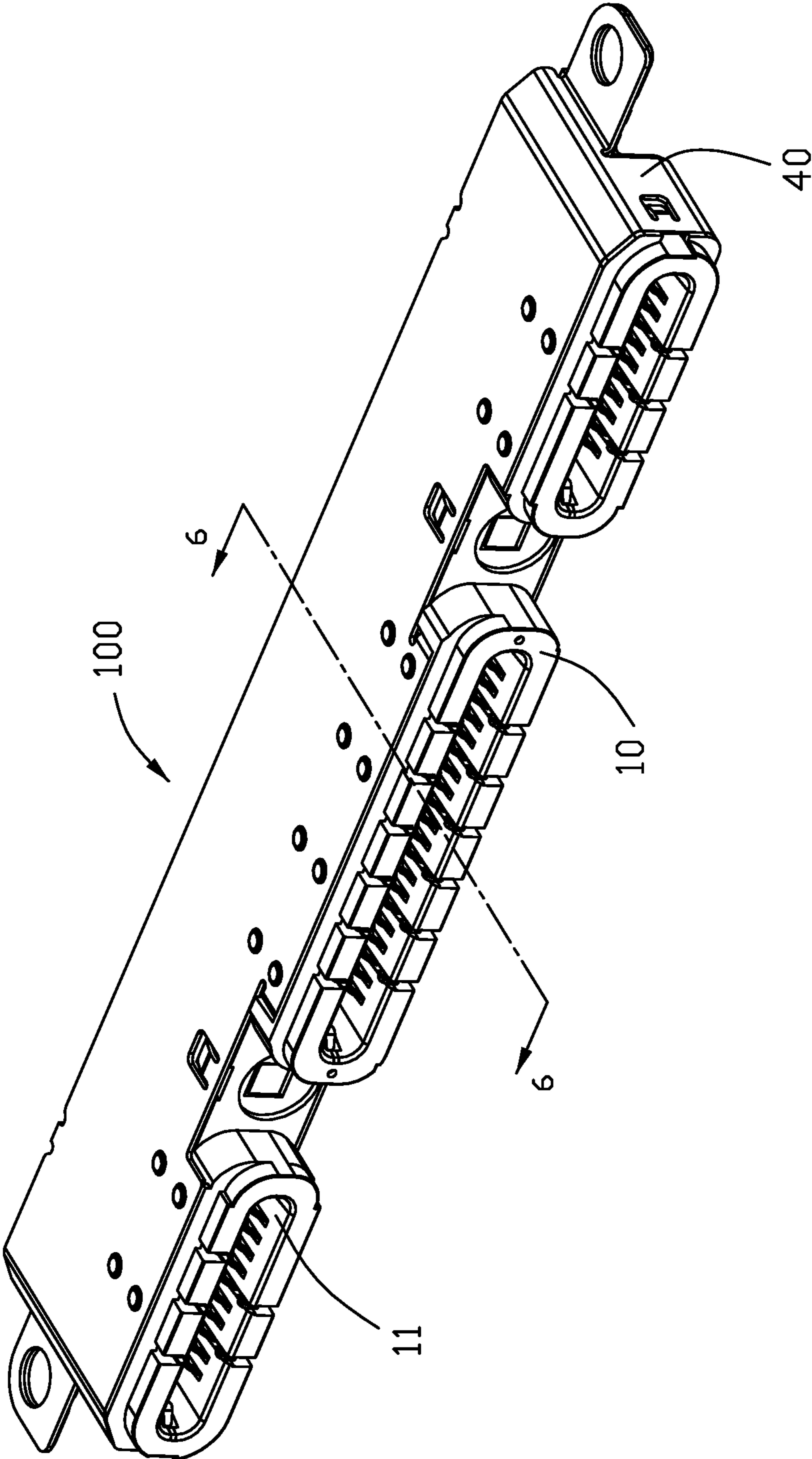

FIG. 1

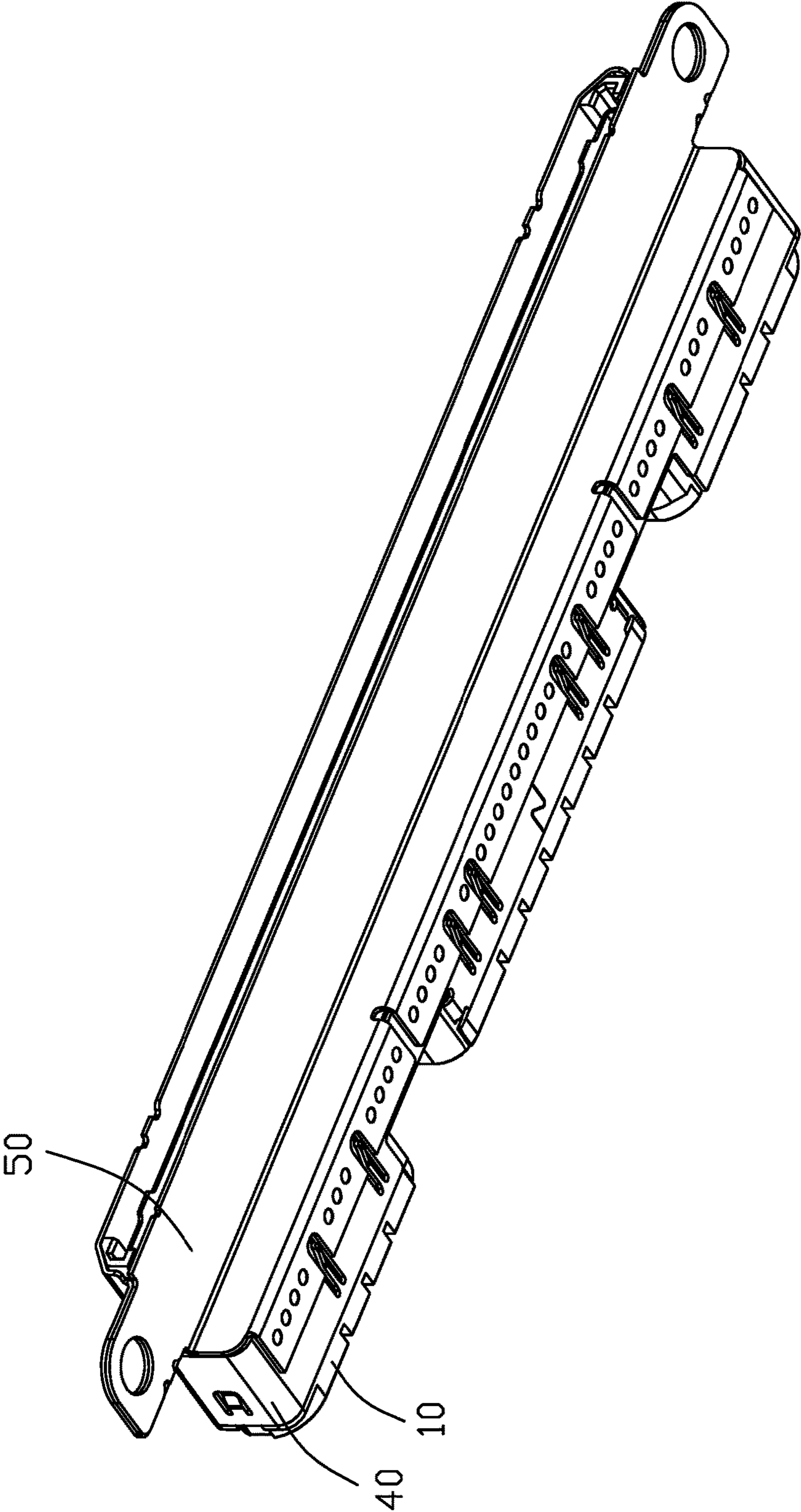

FIG. 2

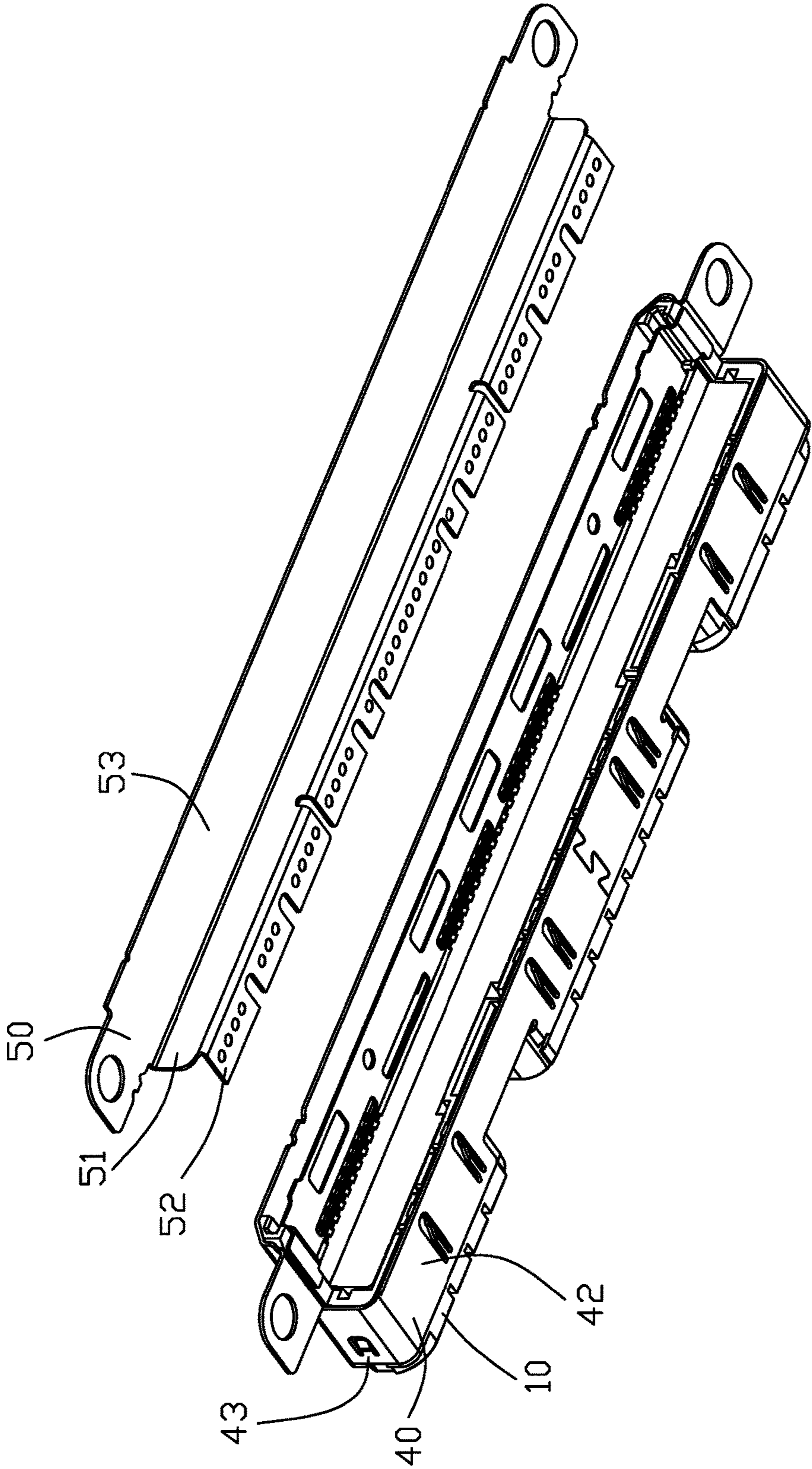

FIG. 3

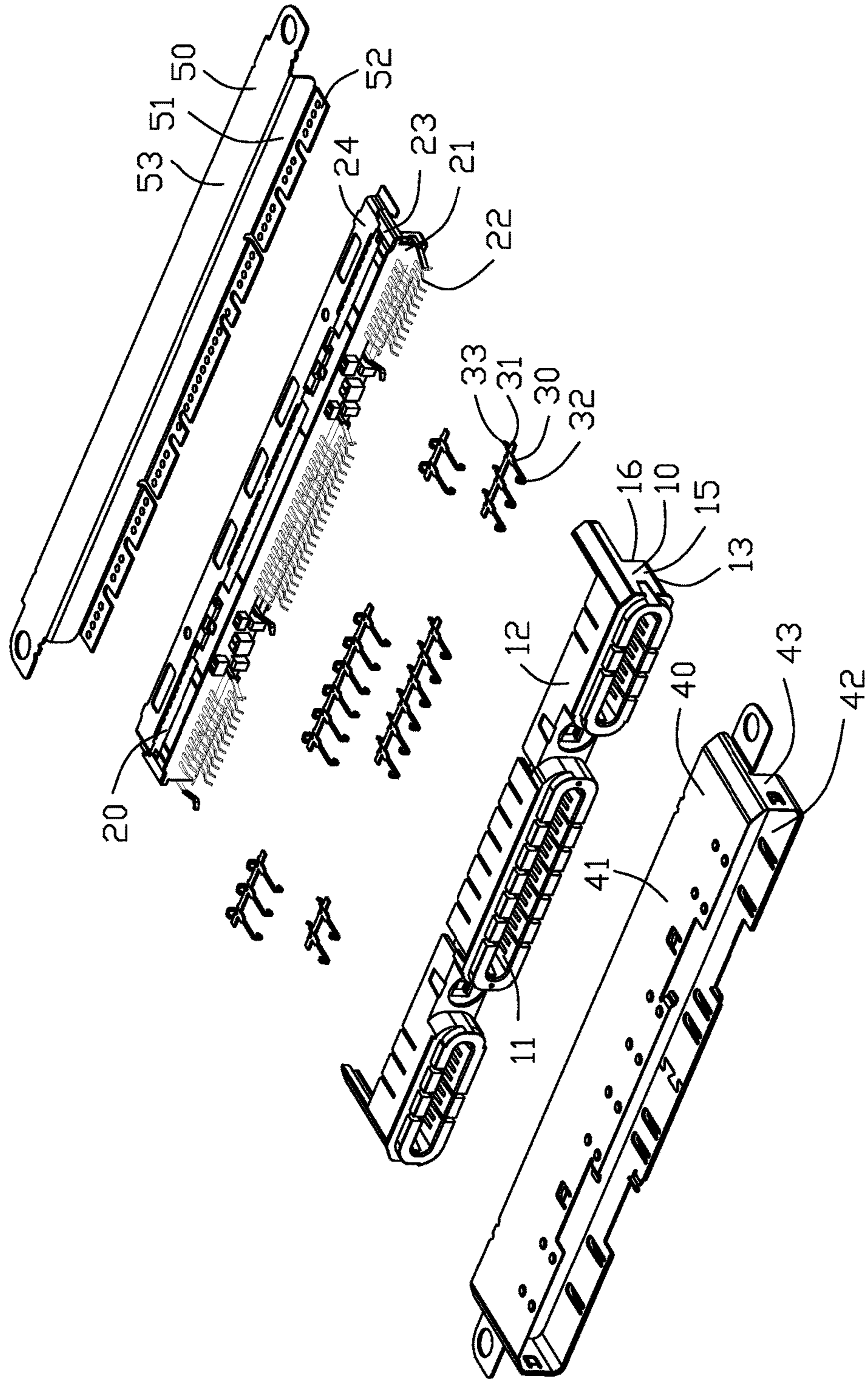

FIG. 4

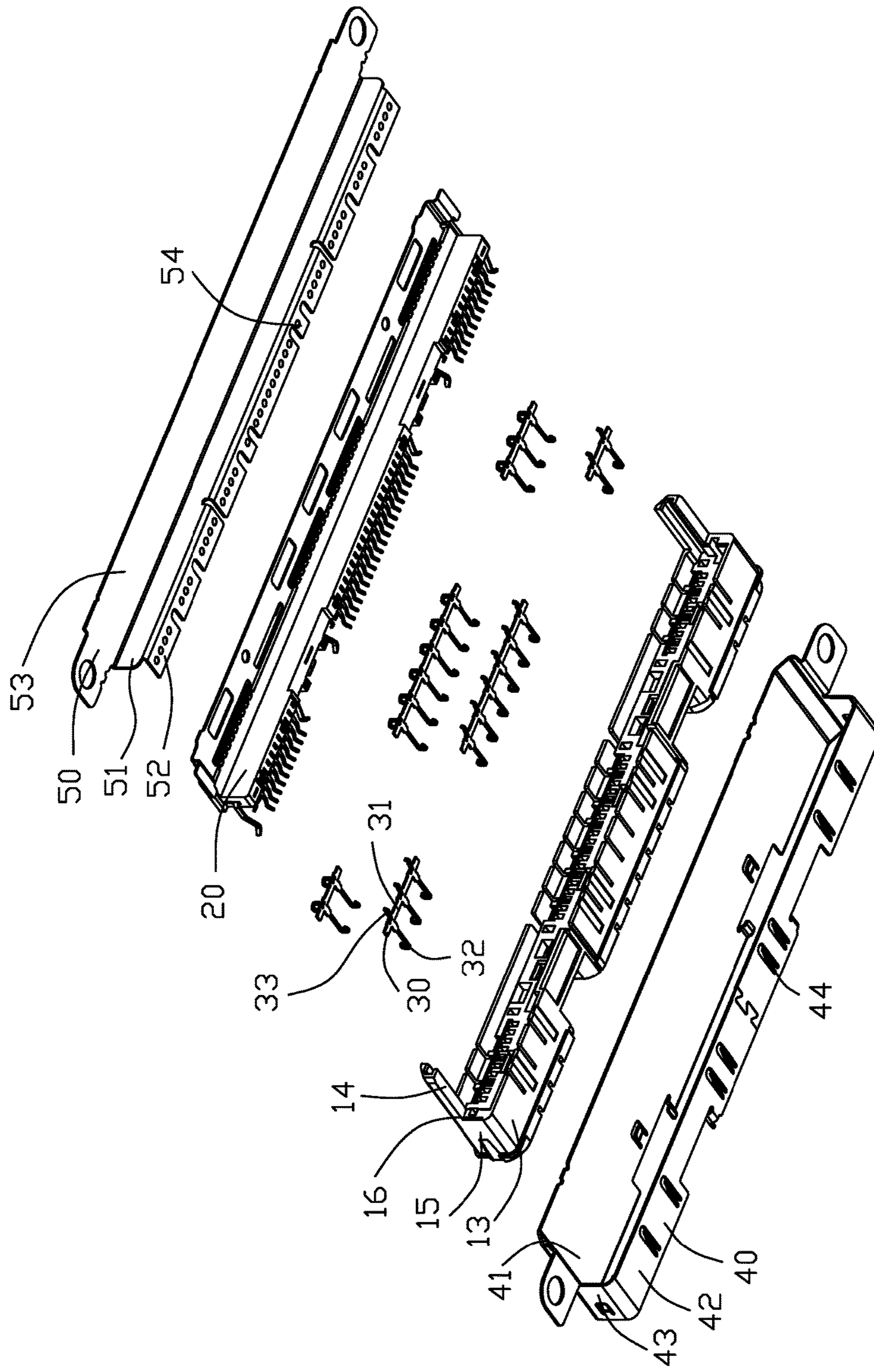

FIG. 5

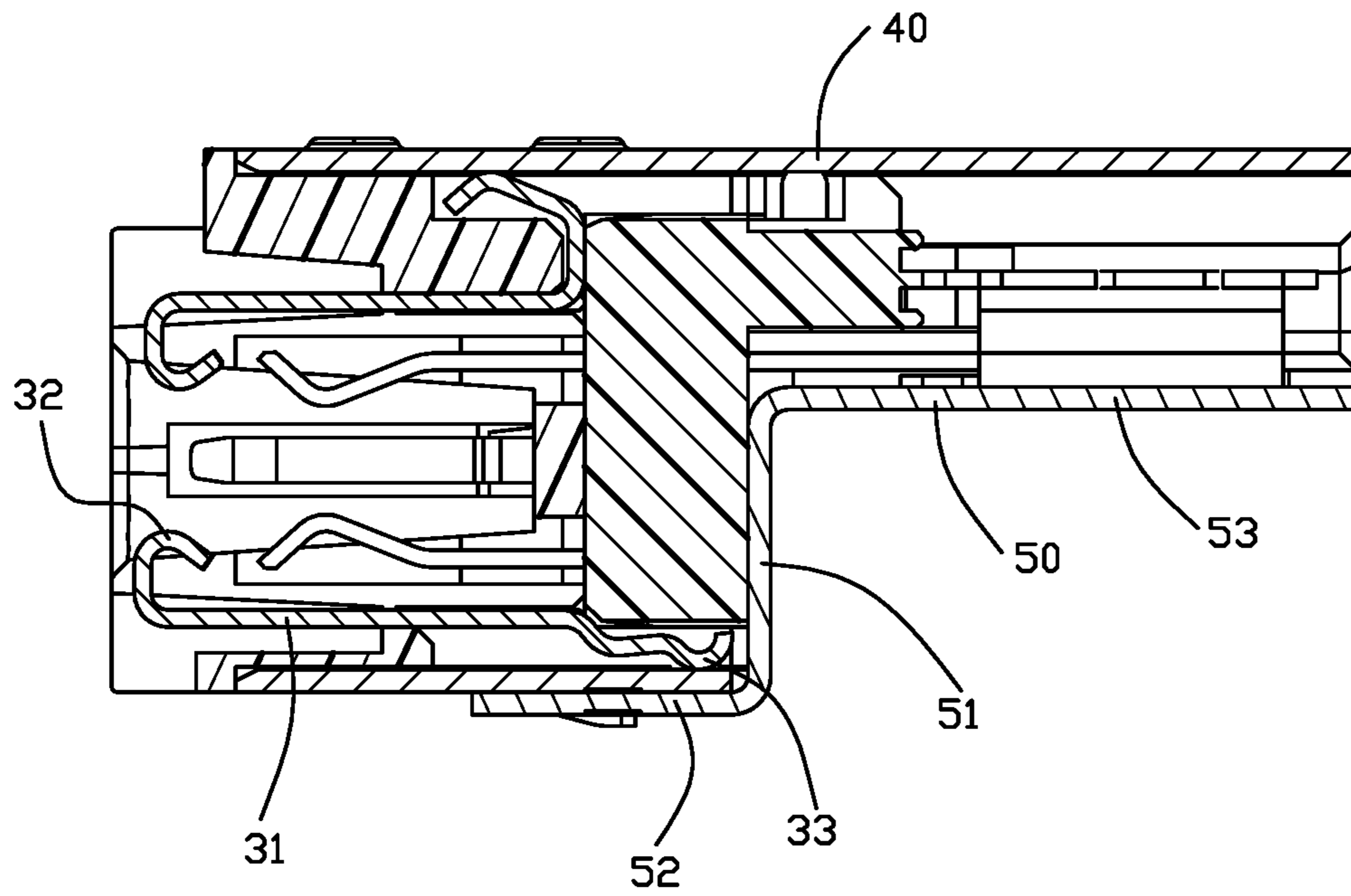

FIG. 6

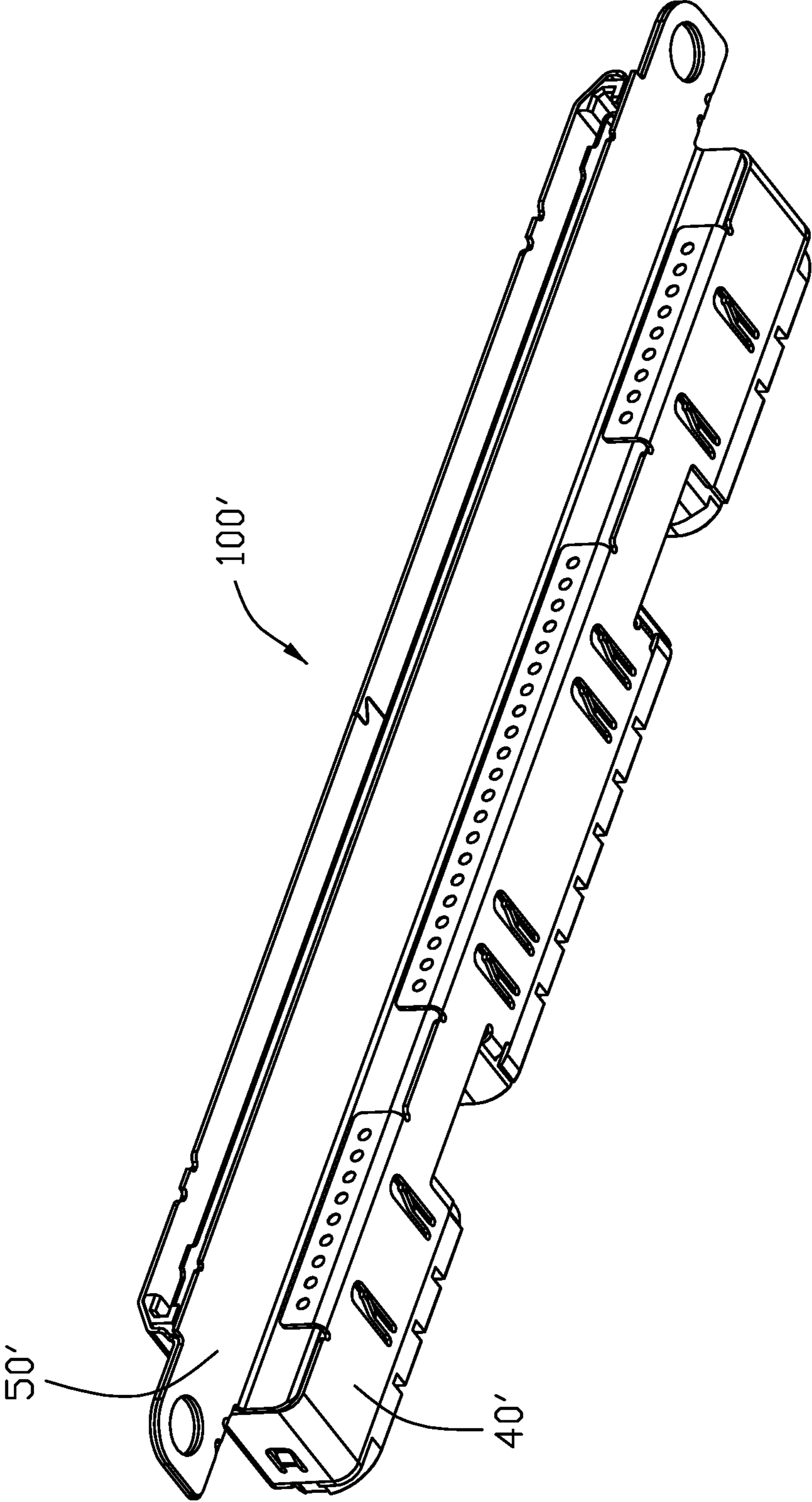

FIG. 7

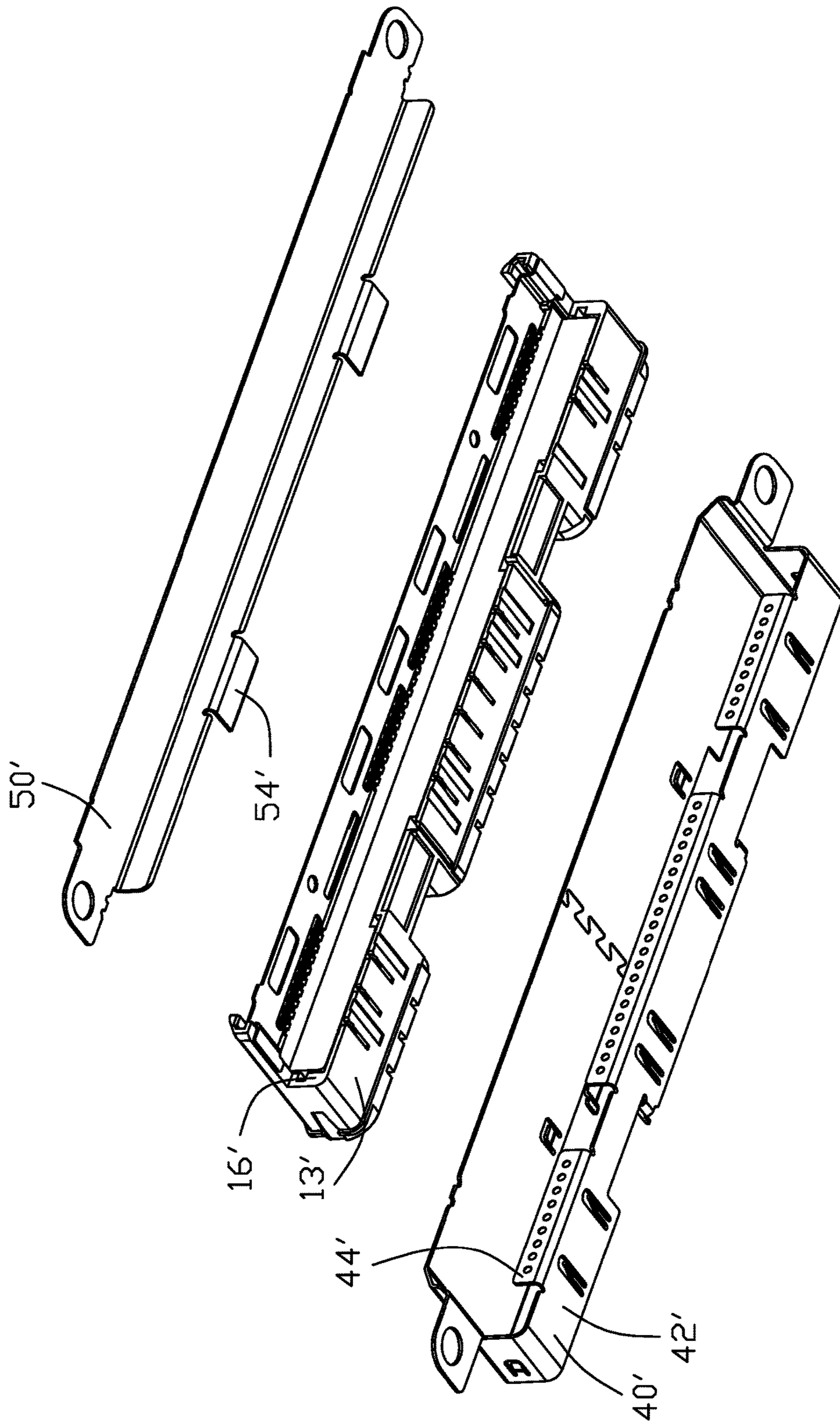

FIG. 8

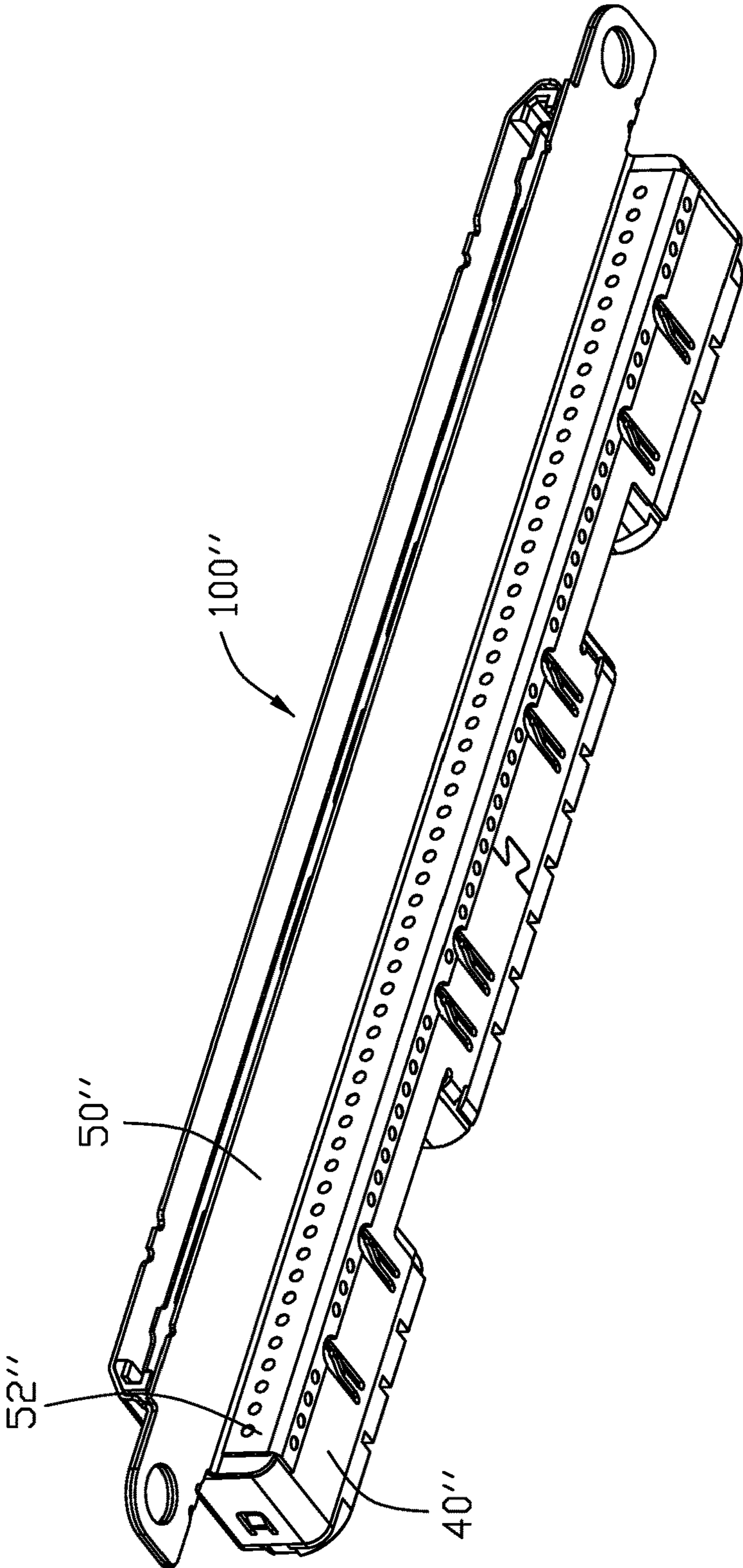

FIG. 9

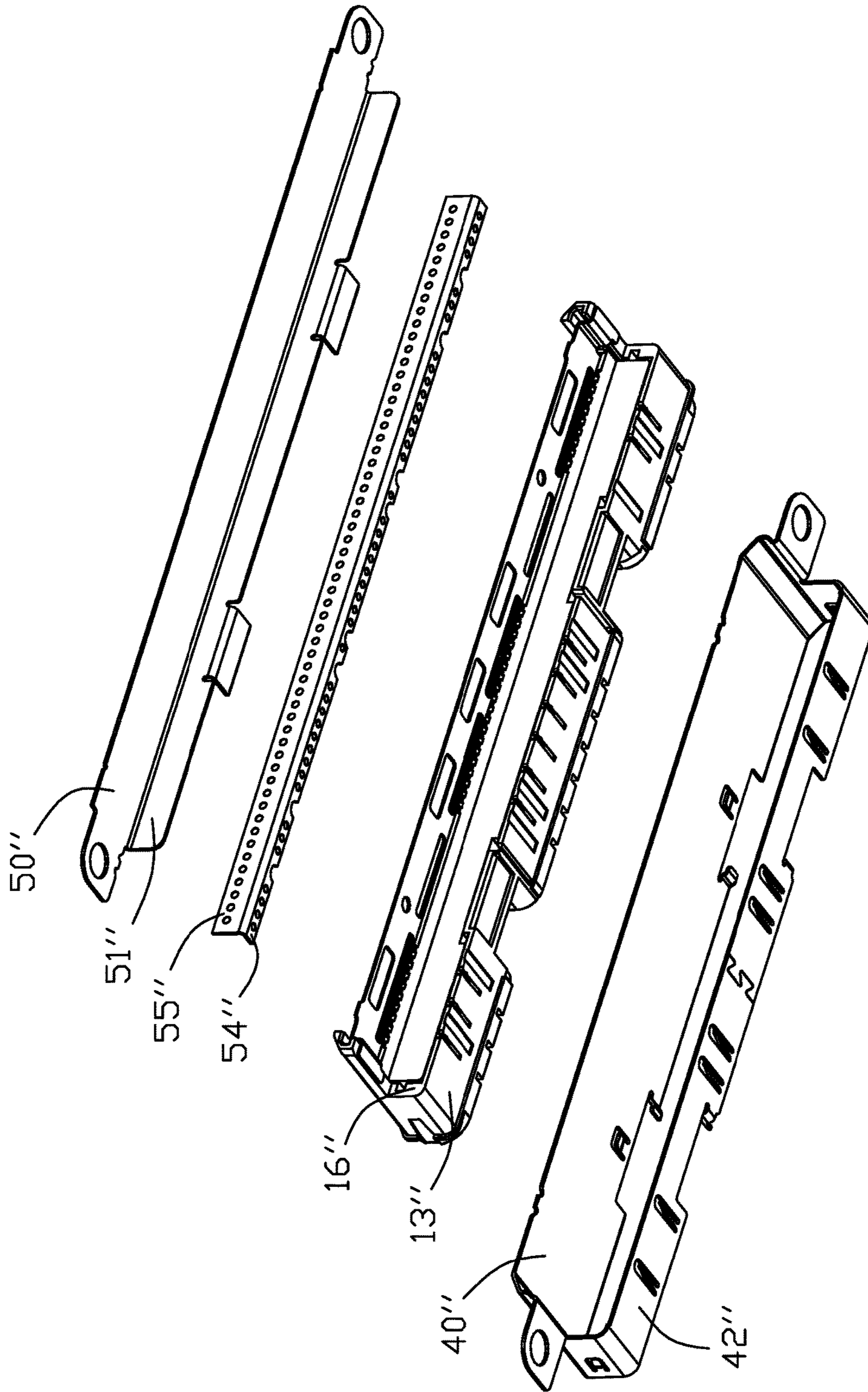

FIG. 10

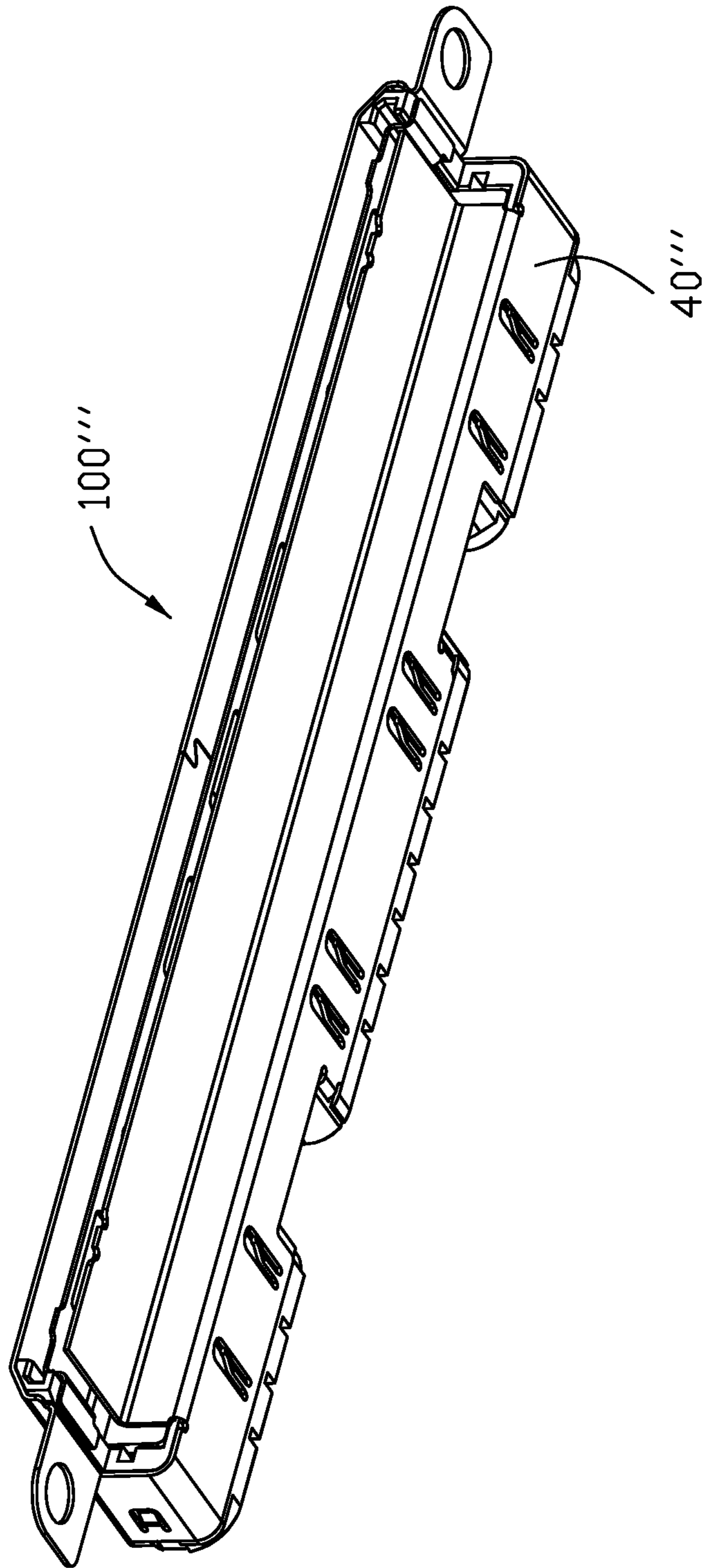

FIG. 11

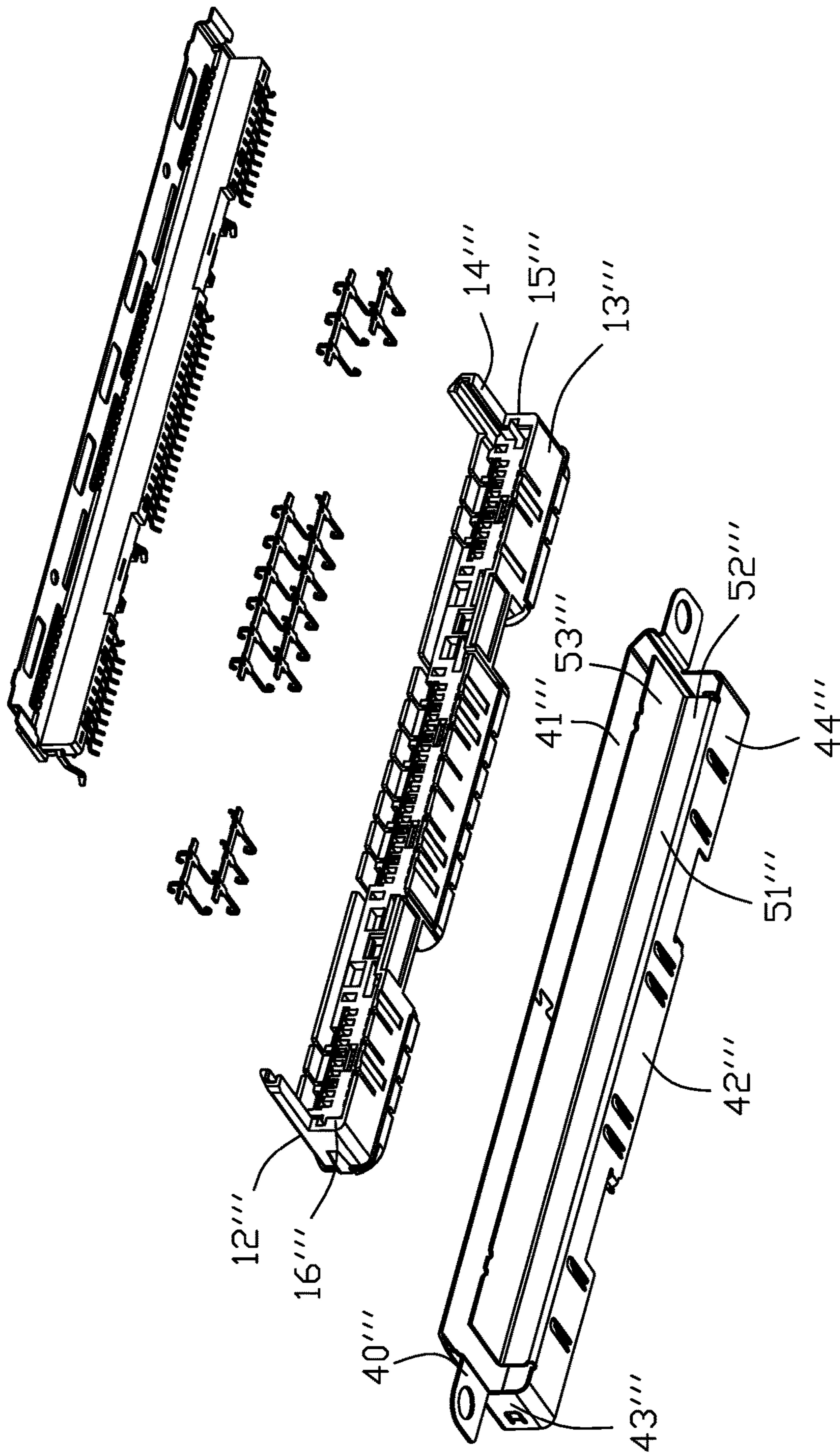

FIG. 12

1**ELECTRICAL CONNECTOR WITH
ADDITIONAL SHIELDING****1. FIELD OF THE INVENTION**

The invention relates to the electrical connector, and particularly to an electrical connector with complete shielding.

2. DESCRIPTION OF RELATED ART

U.S. Pat. No. 9,647,395 discloses an electrical receptacle connector having an insulative housing in a stepped configuration with a frame like metallic primary shell enclosing opposite top and bottom surfaces and two opposite sides surfaces of the housing, and further an L-shaped metallic secondary shell covering the rear stepped structure. Anyhow, a tiny gap may exist between a boundary between the primary shell and the secondary shell, thus resulting in electrical leaking. Understandably, ideally a unitary one piece metallic shell enclosing all surfaces of the housing may have the superior shielding effect. Anyhow, because the housing is not a simple rectangular block, it is not easy to design a one piece unitary metallic shell to cover all the surfaces of the irregularly shaped housing under easy manufacturing and material saving requirements. In addition, the grounding bar used in the connector may not be reliably constantly connected to the metallic shell, thus jeopardizing the whole grounding/shielding effect thereof.

It is desired to have the electrical connector having corresponding metallic shell structure with reliable shielding effect.

SUMMARY OF THE INVENTION

An object of the invention is to provide an electrical connector with an insulative elongated housing and first and second metallic shells covering the housing. The housing includes a top surface, a bottom surface, two sides surfaces and a middle surface between the top surface and the bottom surface so as to form a step structure thereof. The primary shell covers the top surface, the bottom surface and two side surfaces, and the secondary shell covers the middle surface and the rear surface and further the primary shell on the bottom surface in an overlapped manner so as to avoid any electrical leaking along the front-to-back direction between the primary shell and the secondary shell.

Other objects, advantages and novel features of the invention will become more apparent from the following detailed description when taken in conjunction with the accompanying drawings.

BRIEF DESCRIPTION OF THE DRAWINGS

FIG. 1 is a perspective view of an electrical connector of the first preferred embodiment of the invention;

FIG. 2 is another perspective view of the electrical connector of FIG. 1;

FIG. 3 is an exploded perspective view of the electrical connector of FIG. 1;

FIG. 4 is a further exploded perspective view of the electrical connector of FIG. 3;

FIG. 5 is another further exploded perspective view of the electrical connector of FIG. 4;

FIG. 6 is cross-sectional view of the electrical connector of FIG. 1;

2

FIG. 7 is a perspective view of an electrical connector of the second embodiment of the invention;

FIG. 8 is an exploded perspective view of the electrical connector of FIG. 7;

FIG. 9 is a perspective view of an electrical connector of a third embodiment of the invention;

FIG. 10 is an exploded perspective view of the electrical connector of FIG. 9;

FIG. 11 is a perspective view of an electrical connector of a fourth embodiment of the invention; and

FIG. 12 is an exploded perspective view of the electrical connector of FIG. 11.

**DETAILED DESCRIPTION OF THE
PREFERRED EMBODIMENT**

Referring to FIGS. 1-6, an electrical connector **100** includes an insulative elongated housing **10** extending along a longitudinal direction, a contact module **20** assembled to the housing **10**, a plurality of grounding members **30** assembled upon the housing **10**, and a metallic shielding unit composed of a primary shell **40** and a secondary shell **50**. The contact module **20** includes a first insulator **21**, a plurality of contacts **22** integrally formed with the first insulator **21**, a second insulator **23** over-molded upon the first insulator **21**, and an inner shielding plate **24** integrally formed with the second insulator **23**. In fact, because there are two rows of contacts **22**, there are two pieces of the first insulator **21** respectively integrally formed with the corresponding rows of contacts, respectively, via an insert-molding process. The contact module **20** is forwardly assembled into the housing **10** from a rear side of the housing **10**. The housing **10** forms three mating ports **11** rearwardly recessed from a front surface (not labeled) of the housing on a front side. The grounding member **30** includes a base **31**, a plurality of mating sections **32** forwardly extending therefrom into the mating port **11**, and a plurality of connecting sections **33** extending rearwardly therefrom to contact the primary shell **40**. In this embodiment, as shown in FIG. 6 the connecting section **33** of the upper grounding member **30** is tightly sandwiched between the housing **10** and the insulator of the contact module **20** in the front-to-back direction, and further deflectably and resiliently sandwiched between the housing **10** and the primary shell **40** in the vertical direction perpendicular to the front-to-back direction, while the connecting section **33** of the lower grounding member **30** cooperates with the additional section **52** of the secondary shell **50** to sandwich the lower wall **42** of the primary shell **40** both of which will be illustrated later. The housing **10** includes opposite top surface **12** and bottom surface **13** in a vertical direction perpendicular to the longitudinal direction, a middle downward surface **14** which is formed on each rearwardly extending side arm (not labeled) and located between the top surface **12** and the bottom surface **13** in the vertical direction, a pair of side surfaces **15** in the longitudinal direction, and a vertical rear/rearward surface **16** joined with the middle surface **14** and facing rearwardly in a front-to-back direction perpendicular to both the vertical direction and the longitudinal direction. The primary shell **40** has a frame configuration with an upper wall **41**, a lower wall **42** and two side walls **43** to respectively cover the corresponding top surface **12**, the bottom surface **13** and two side surfaces **15**. The secondary shell **50** of a Z-shaped cross-section, includes a first section **51** to cover the rearward surface **16**, a second section **53** to cover the middle surface **14**, and further an additional section **52** forwardly extending from a bottom edge of the first section **51** to be

3

welded upon the lower wall **42** in an overlapped manner. Notably, both the primary shell **40** and the secondary shell **50** have the corresponding mounting ears (not labeled) at two longitudinal ends around the middle surface **14** for securing. The additional section **52** forms a plurality of cutouts **54** to allow extension of the outwardly extending spring tangs **44** to outwardly protrude therethrough. Notably, as shown in FIG. **6** even though a space is formed around the connecting section **33**, the EMI (Electro-Magnetic Interference) leading along the front-to-back direction thereabouts may be avoided due to continuous extension between the first section **51** and the additional section **52** around the corresponding joined corner between the bottom surface **13** and the rearward surface **16**. In opposite, in the aforementioned U.S. Pat. No. 9,647,395 the possible EMI leaking along the front-to-back direction may exist due to lacking the additional section of the secondary shell overlapping with the lower wall of the primary shell.

Referring to FIGS. **7** and **8**, in the connector **100'** on one hand the first shell **40'** further includes a plurality of vertical addition sections **44'** extending upwardly from a rear edge of the lower wall **42'** to be welded behind the vertical first section (not labeled) of the secondary shell **50'**. On the other hand, in the secondary shell **50** the additional section **54'** is arranged to be alternate with the additional sections **44'** in the longitudinal direction. The additional section **54'** is received within a shallow recess (not labeled) in the bottom surface **13'**, and the lower wall **42'** cooperates with the bottom surface **13'** to sandwich there additional section **54** therebetween in the vertical direction. Notably, similar to the additional section **54'**, the additional sections **44** may prevent EMI leaking around the corner between the bottom surfaced **13'** and the rearward surface **16'** along the front-to-back direction.

Referring to FIGS. **9** and **10**, in the connector **100''** a discrete addition piece **52''**, either a metal plate or a conductive glue layer, is located behind and second shell **50''** and under the primary shell **40''**. The L-shaped addition piece **52''** includes a first section **54''** welded on and located below the lower wall **42''** in the vertical direction, and a second section **55''** welded on and located behind the first section **51''** of the secondary shell **50''** in the front-to-back direction so as to seal any possible leak around the corner of the bottom surface **13''** and the rearward surface **16''**.

Referring to FIGS. **11** and **12**, in the connector **100'''**, the primary shell **40'''** includes a main part **44'''** and an additional part **52'''**. The main part **44'''** includes an upper wall **41'''**, a lower wall **42'''** and a pair of side walls **43'''**. The addition part **52'''** includes a first section **51'''** extending upwardly from a rear edge of the lower wall **42'''**, and a second section **53'''** extending from an upper edge of the first section **51'''**. The upper wall **41'''** covers the top surface **12'''**, the lower wall **42'''** covers the bottom surface **13'''**, the two side walls **43'''** cover the side surfaces **15'''**. The first section **51'''** covers the rear surface **16'''**, and the second section **53'''** covers the middle surface **14'''**. Understandably, because of the unitary one piece structure of the primary shell **40'''** around the corner between the rearward surface **16'''** and the bottom surface **13'''**, the shielding effect is reliable.

It is to be understood, however, that even though numerous characteristics and advantages of the present invention have been set forth in the foregoing description, together with details of the structure and function of the invention, the disclosure is illustrative only, and changes may be made in detail, especially in matters of shape, size, and arrangement of parts within the principles of the invention to the full

4

extent indicated by the broad general meaning of the members in which the appended claims are expressed.

What is claimed is:

1. An electrical connector comprising:

a contact module including a plurality contacts retained in an insulator;

an insulative elongated housing, in which the contact module is received, extending along a longitudinal direction to define opposite top and bottom surfaces in a vertical direction perpendicular to the longitudinal direction, a pair of side surfaces along the longitudinal direction, and opposite front and rear surfaces in a front-to-back direction perpendicular to both the longitudinal direction and the vertical direction, said housing further defining a horizontal rear middle surface between the top surface and the bottom surface in the vertical direction and a vertical rearward surface roughly joined with the middle surface and rearwardly facing in the front-to-back direction;

a metallic shielding unit including:

a one piece primary shell being of a frame structure and forming a top wall covering the top surface, a lower wall covering a bottom surface, a pair of side walls covering the pair of side surfaces; and

a one piece Z-shaped secondary shell forming a vertical first section covering the rearward surface, a horizontal second section extending from an upper edge of the first section to cover the middle surface, and further an addition section extending from a lower edge of the first section to be located below and welded to the lower wall so as to prevent any EMI (Electro-Magnetic Interference) leakage, in the front-to-back direction, between the primary shell and the secondary shell around a corner between the bottom surface and the rearward surface of the housing.

2. The electrical connector as claimed in claim **1**, wherein the lower wall forms a plurality of outwardly extending spring tangs, and the additional section forms a plurality of cutouts to allow said spring tangs to protrude outwardly therethrough.

3. The electrical connector as claimed in claim **1**, further including a plurality of conductive grounding members assembled upon the housing with connecting sections deflectably mechanically and electrically contact the primary shell in the vertical direction.

4. The electrical connector as claimed in claim **3**, wherein said connecting sections are further sandwiched between the housing and the insulator of the contact module in the front-to-back direction.

5. The electrical connector as claimed in claim **3**, wherein the lower wall is sandwiched between the additional section of the secondary shell and the connecting section of the grounding member.

6. An electrical connector comprising:

a contact module including a plurality contacts retained in an insulator;

an insulative elongated housing, in which the contact module is received, extending along a longitudinal direction to define opposite top and bottom surfaces in a vertical direction perpendicular to the longitudinal direction, a pair of side surfaces along the longitudinal direction, and opposite front and rear surfaces in a front-to-back direction perpendicular to both the longitudinal direction and the vertical direction, said housing further defining a horizontal rear middle surface between the top surface and the bottom surface in the vertical direction and a vertical

5

rearward surface roughly joined with the middle surface and rearwardly facing in the front-to-back direction;

a metallic shielding unit including:

a primary shell being of a frame structure and forming a top wall covering the top surface, a lower wall covering a bottom surface, a pair of side walls covering the pair of side surfaces;

a secondary shell forming a vertical first section covering the rearward surface, a horizontal second section extending from an upper edge of the first section to cover the middle surface; wherein

said shielding unit further includes an additional section at least partially overlapped with the lower wall of the primary shell in the vertical direction, and welding is applied to at least two of said primary shell, said secondary shell and the additional sections so as to prevent any EMI (Electro-Magnetic Interference) leakage, in the front-to-back direction, between the primary shell and the secondary shell around a corner between the bottom surface and the rearward surface of the housing.

7. The electrical connector as claimed in claim 6, wherein said additional section unitarily extends from a bottom edge of the first section of the secondary shell.

8. The electrical connector as claimed in claim 7, wherein the additional section of the secondary shell is located under the lower wall of the primary shell with the welding applied therebetween.

9. The electrical connector as claimed in claim 7, wherein the housing forms a recess in the bottom surface to receive the additional section of the secondary shell.

10. The electrical connector as claimed in claim 9, wherein said additional section is sandwiched between the bottom surface of the housing and the lower wall of the primary shell.

11. The electrical connector as claimed in claim 10, wherein said primary shell further includes another additional section extending upwardly from a rear edge of the lower wall to be located behind and forwardly butting against the first section of the secondary shell in the front-to-back direction.

12. The electrical connector as claimed in claim 11, wherein the additional section of the secondary shell and the additional section of the primary shell are offset from each other in the longitudinal direction.

6

13. The electrical connector as claimed in claim 11, wherein the additional section of the primary shell is welded to the first section of the secondary shell.

14. The electrical connector as claimed in claim 6, wherein said additional section belongs to an L-shaped addition piece discrete from both the primary shell and the secondary shell and having said additional section welded under the lower wall of the primary shell and another additional section unitarily extending from a rear edge of said addition section to be located behind and welded upon the first section of the secondary shell.

15. An electrical connector comprising:

a contact module including a plurality contacts retained in an insulator;

an insulative elongated housing, in which the contact module is received, extending along a longitudinal direction to define opposite top and bottom surfaces in a vertical direction perpendicular to the longitudinal direction, a pair of side surfaces along the longitudinal direction, and opposite front and rear surfaces in a front-to-back direction perpendicular to both the longitudinal direction and the vertical direction, said housing further defining a horizontal rear middle surface between the top surface and the bottom surface in the vertical direction and a vertical rearward surface roughly joined with the middle surface and rearwardly facing in the front-to-back direction;

a metallic shielding unit including:

a primary shell being of a frame structure and forming a top wall covering the top surface, a lower wall covering a bottom surface, a pair of side walls covering the pair of side surfaces; and

a secondary shell forming a vertical first section covering the rearward surface, a horizontal second section extending from an upper edge of the first section to cover the middle surface; wherein

the vertical first section of the secondary shell unitarily extends from a rear edge of the lower wall of the primary shell so as to prevent any EMI (Electro-Magnetic Interference) leakage, in the front-to-back direction, between the primary shell and the secondary shell around a corner between the bottom surface and the rearward surface of the housing.

* * * * *