



US 20020055390A1

(19) **United States**

(12) **Patent Application Publication**
Mizukoshi et al.

(10) **Pub. No.: US 2002/0055390 A1**

(43) **Pub. Date: May 9, 2002**

(54) **CONSTANT VELOCITY JOINT OF TRIPOD TYPE**

Publication Classification

(76) Inventors: **Yasumasa Mizukoshi**, Fujisawa-Shi (JP); **Minoru Ishijima**, Isesaki-Shi (JP); **Toshihiro Ikeda**, Takasaki-Shi (JP)

(51) **Int. Cl.⁷** **F16D 3/26**
(52) **U.S. Cl.** **464/111**

Correspondence Address:
Reising, Ethington, Barnes, Kisselle
Learman & McCulloch, P.C.
5291 Colony Drive North
Saginaw, MI 48603 (US)

(57) **ABSTRACT**

The object of the invention is to provide a constant velocity joint of tripod type which is both highly strong and durable, and which can minimize rolling resistance when transmitting torque at a joint angle. A tripod type constant velocity joint comprises a housing secured to a first rotating shaft and a tripod having trunnion axes spaced apart equally in a circumferential direction and securing equally to the second rotating shaft. The cross section normal to the trunnion axis is shaped to an ellipse and the direction of its short diameter is arranged parallel to the second rotational shaft.

(21) Appl. No.: **09/977,778**

(22) Filed: **Oct. 15, 2001**

(30) **Foreign Application Priority Data**

Oct. 16, 2000 (JP) 2000-315523

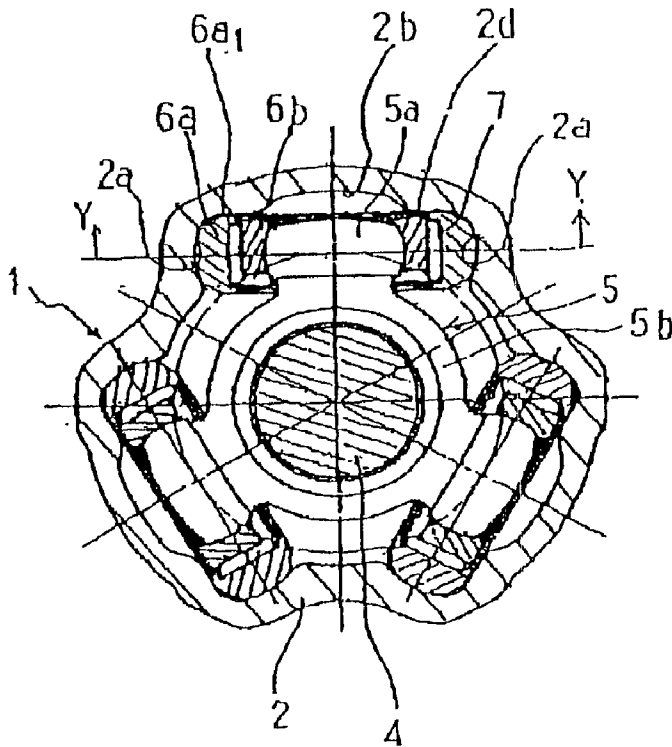

Fig. 1

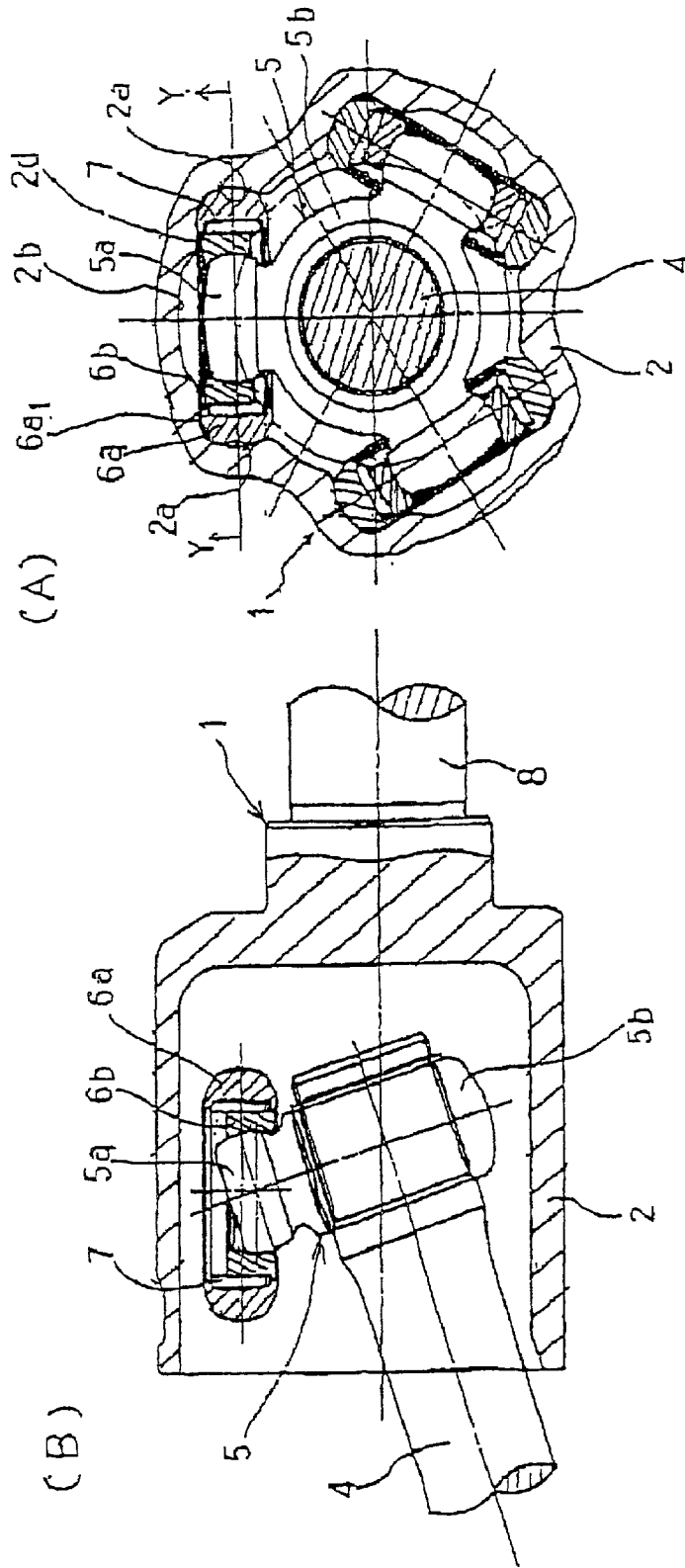
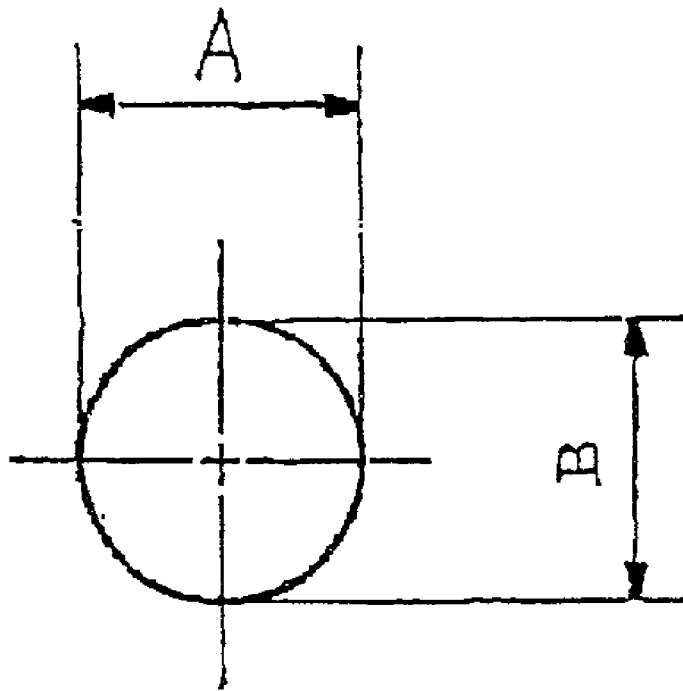

Fig. 2



Y-Y SECTIONAL VIEW
(TRUNNION AXIS)

Fig. 3

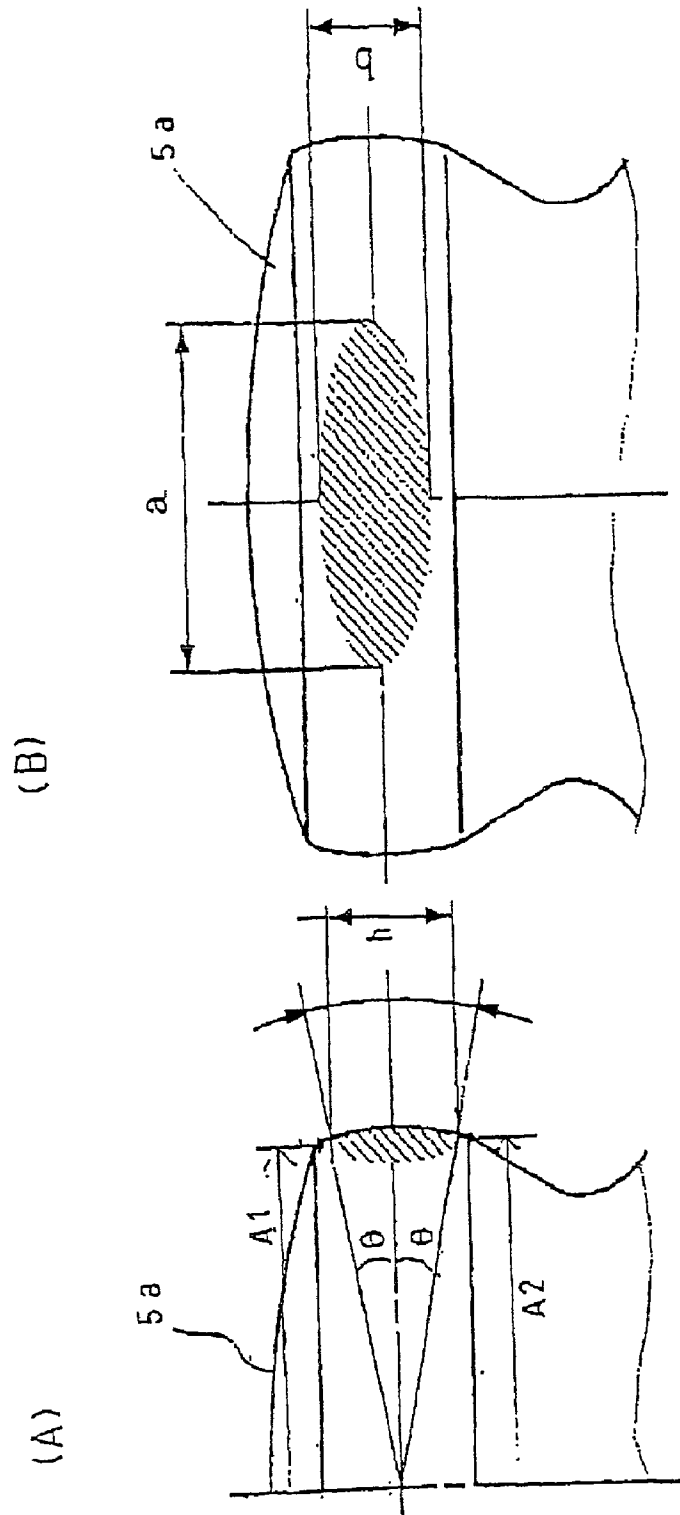

Fig. 4

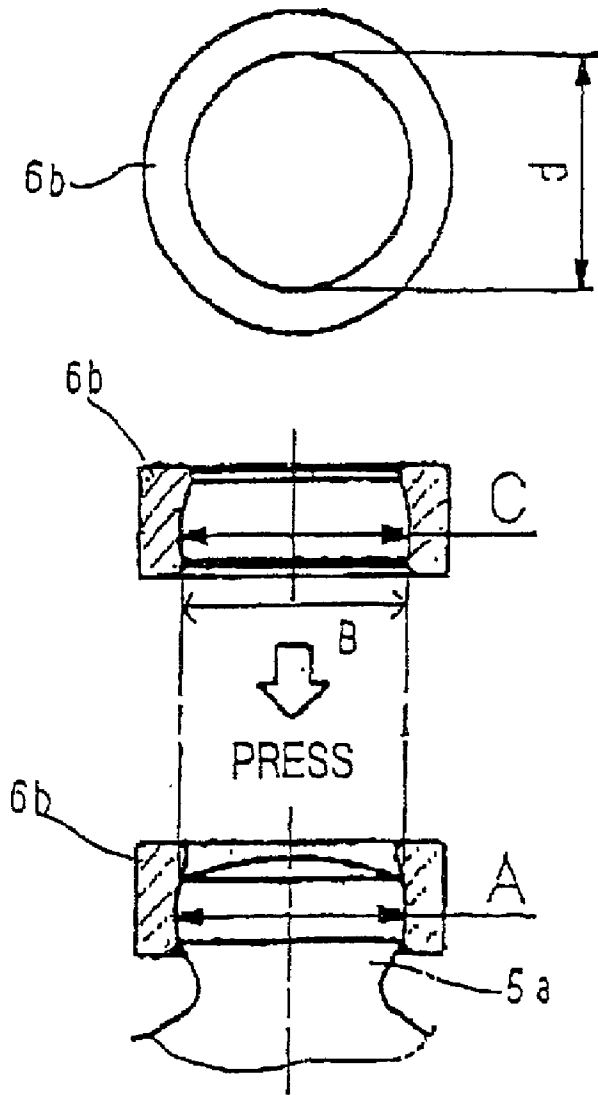

Fig. 5

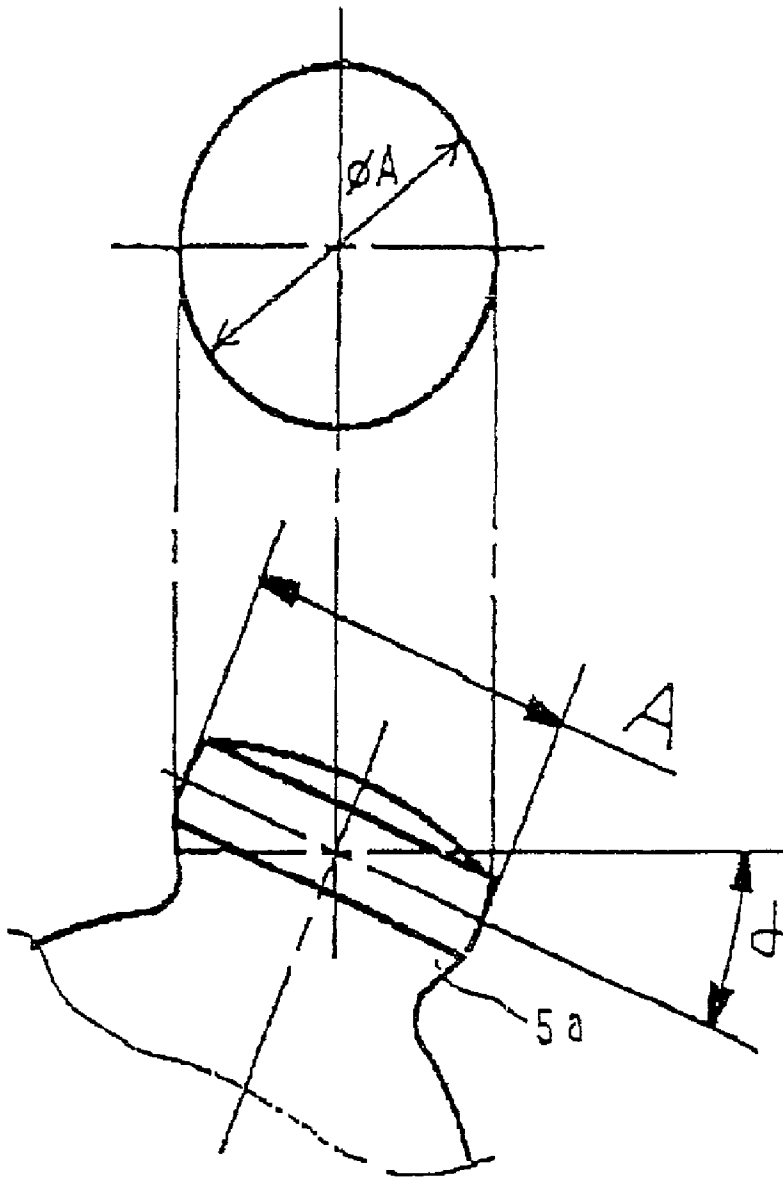

Fig. 6

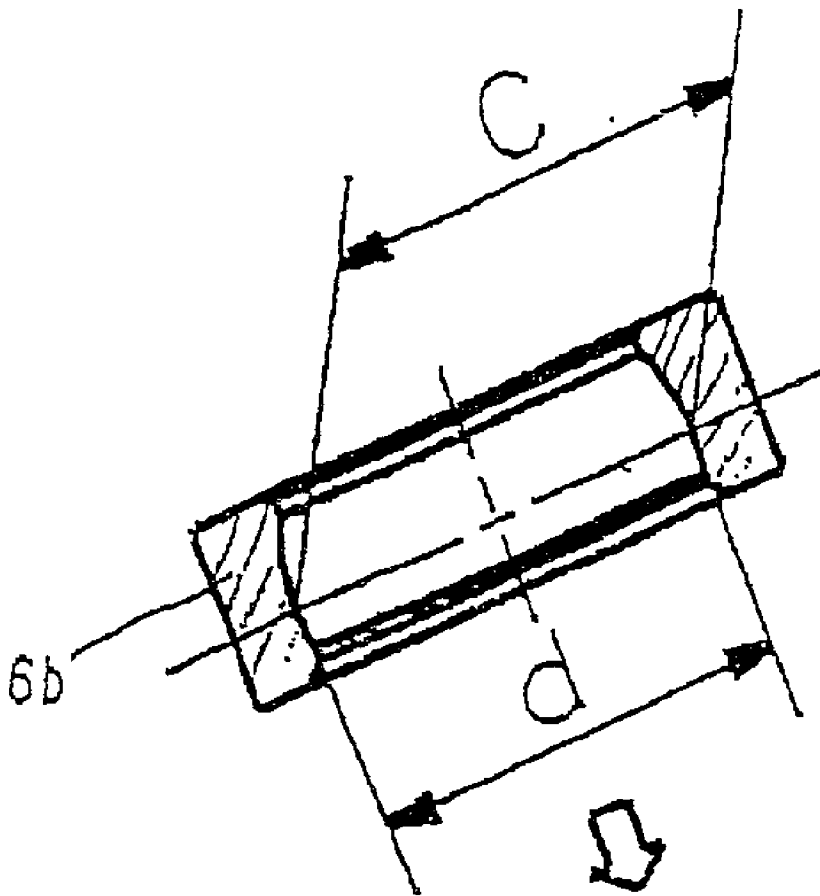

Fig. 7

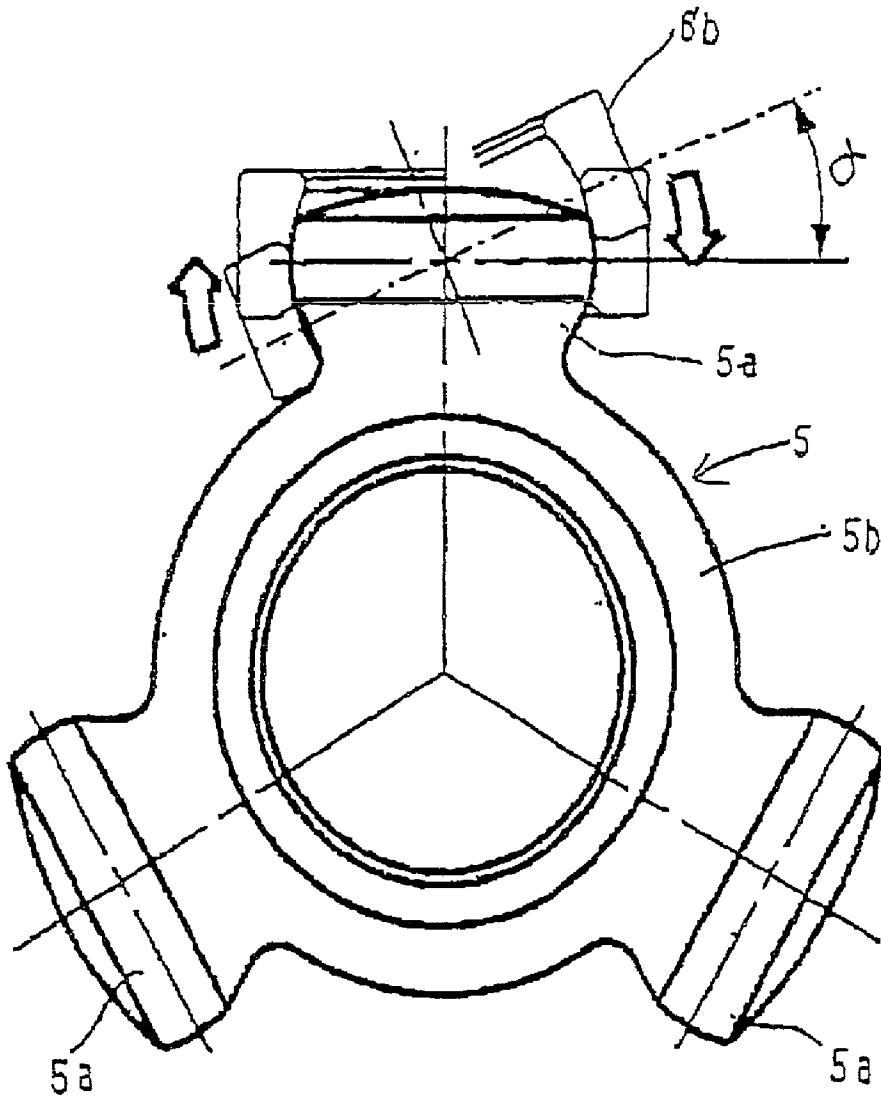

Fig. 8

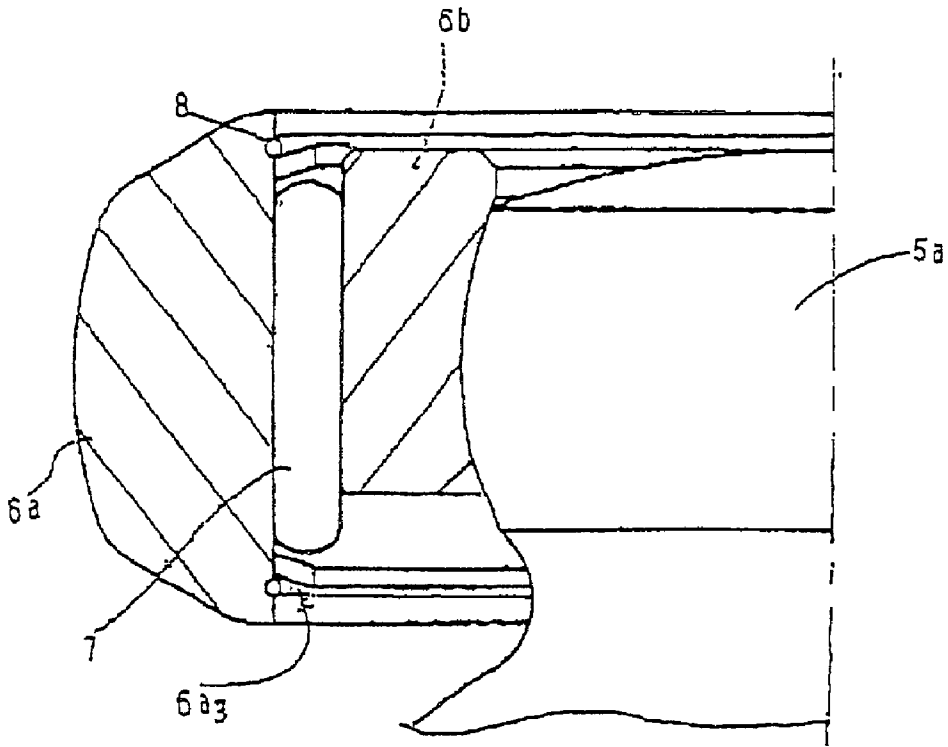

Fig. 9

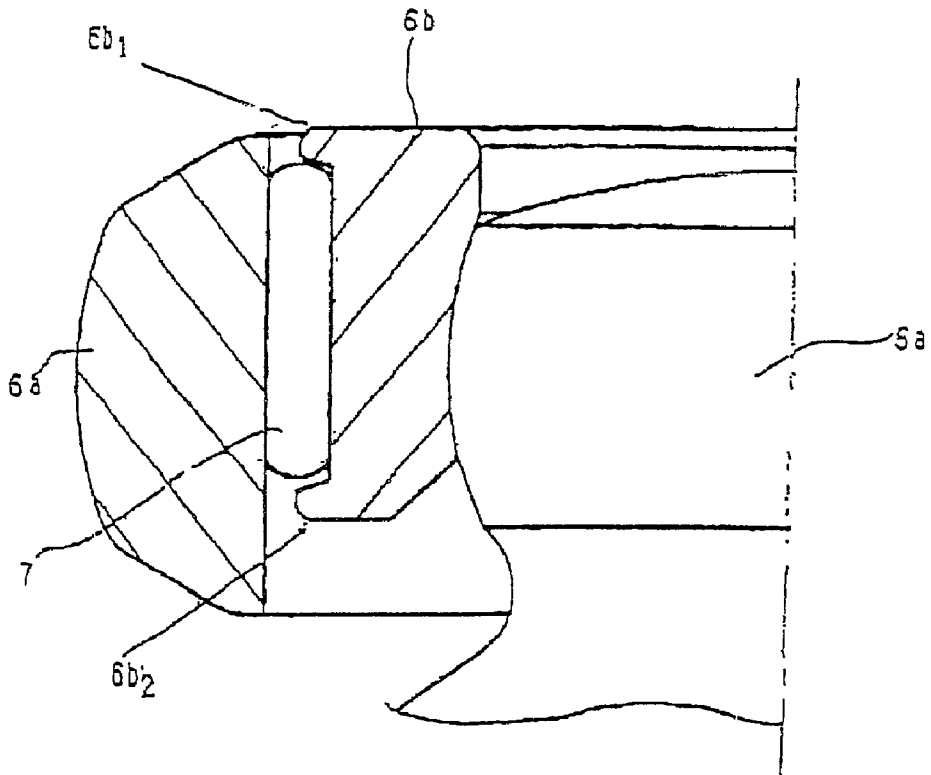

Fig. 10

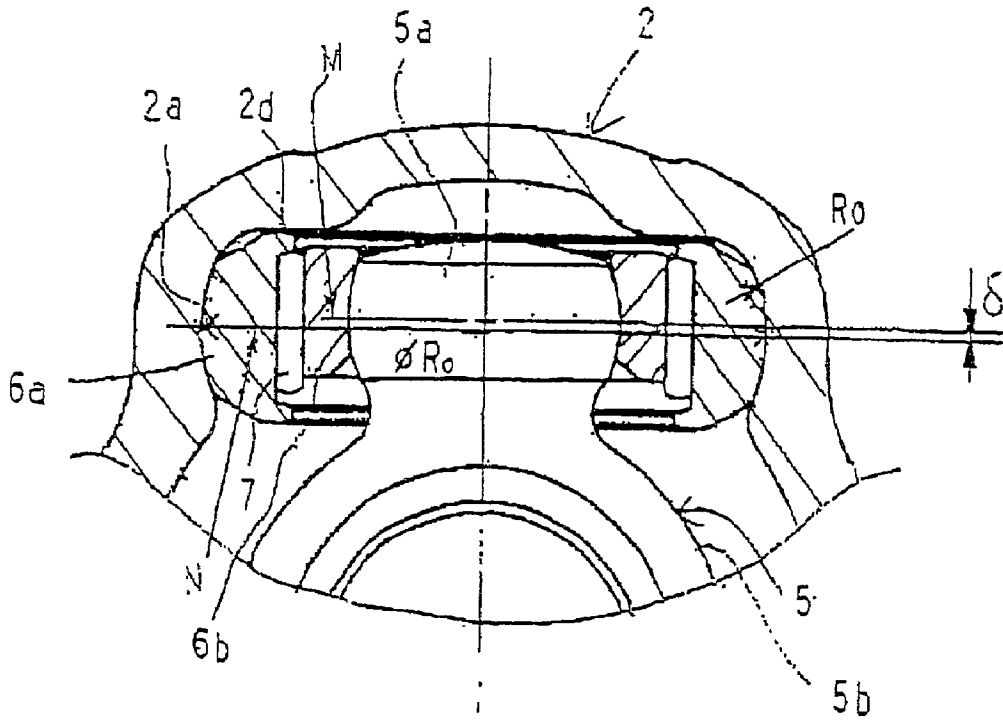

Fig. 11

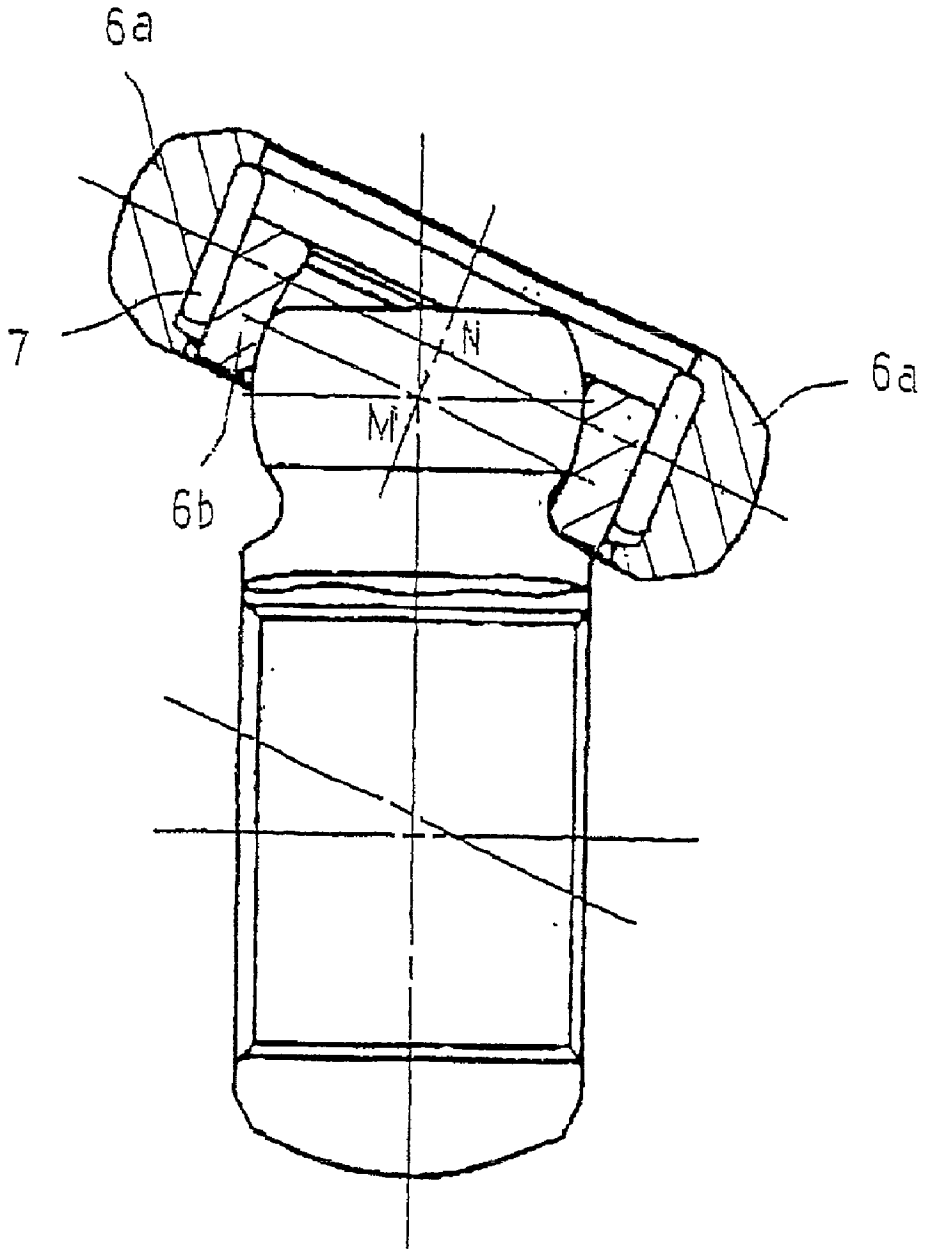

Fig. 12

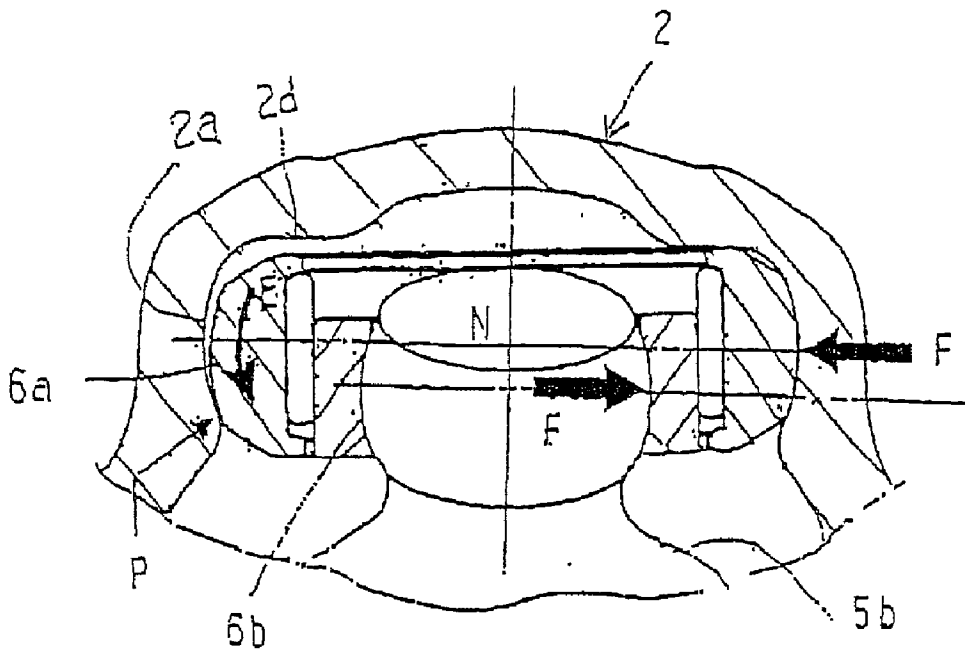

Fig. 13

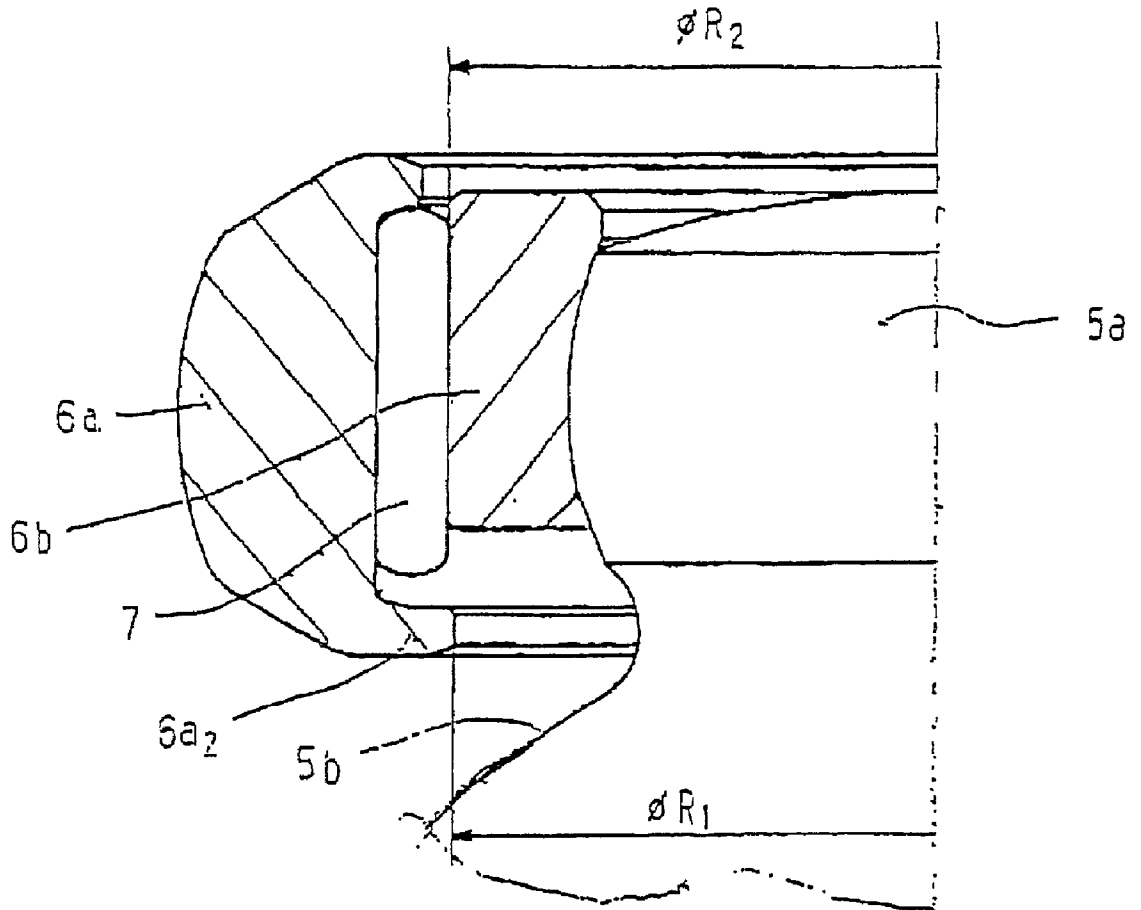

Fig. 14

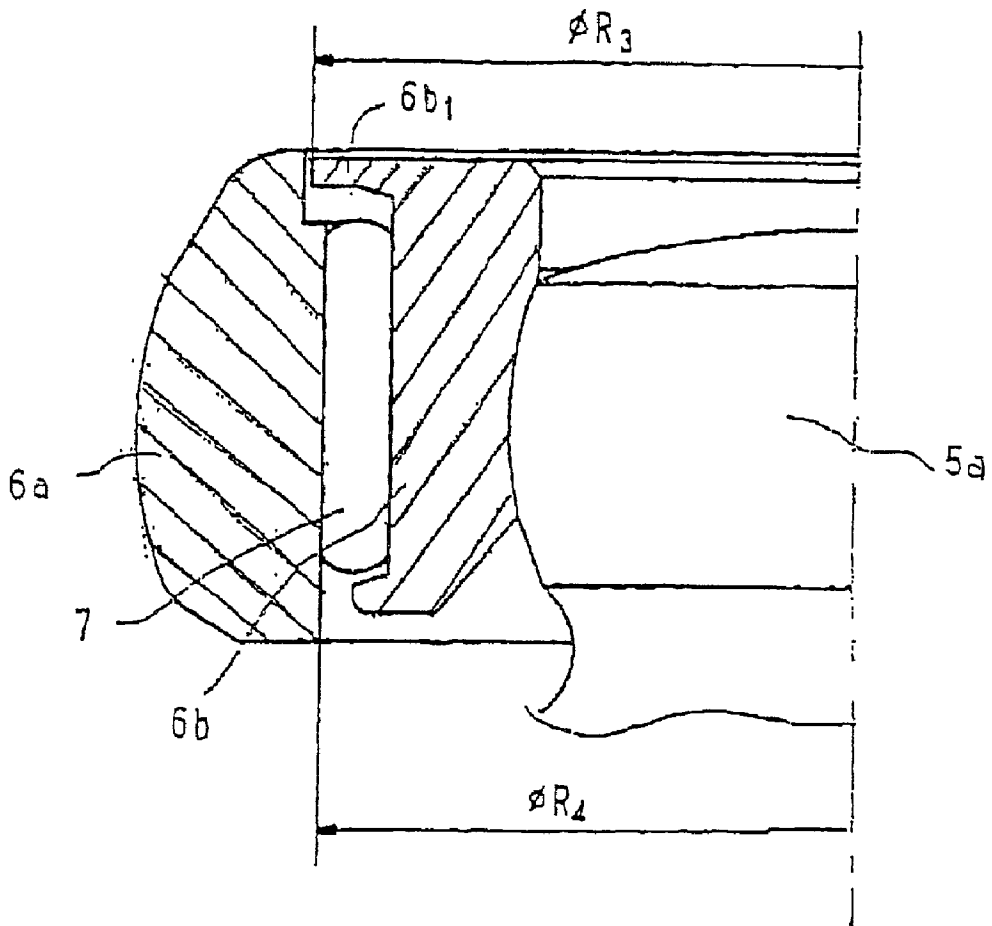

Fig. 15

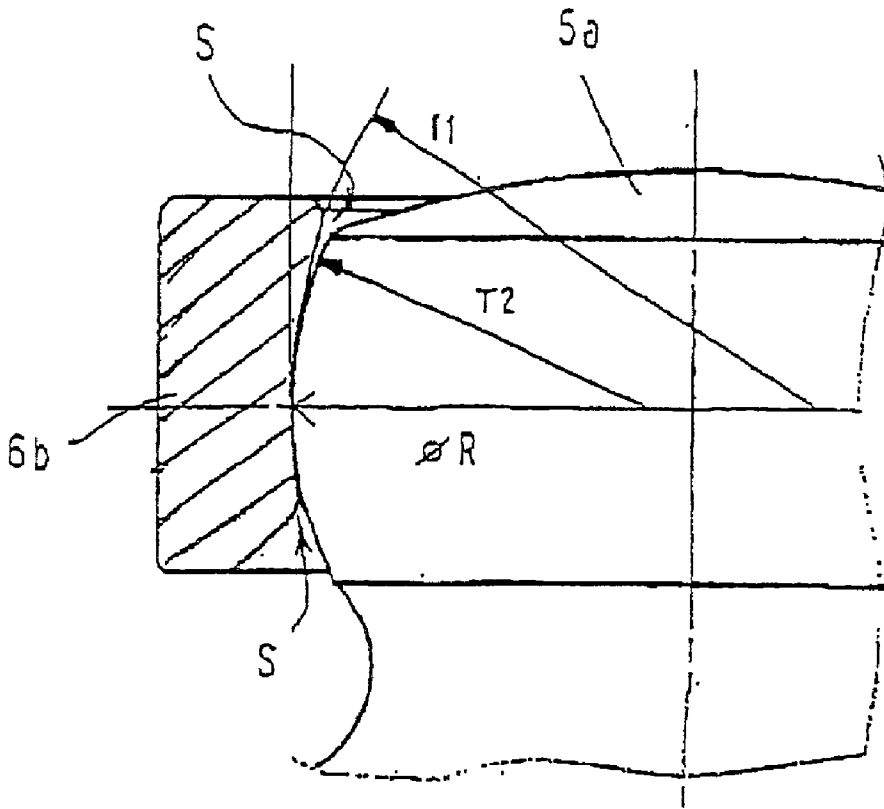

Fig. 16

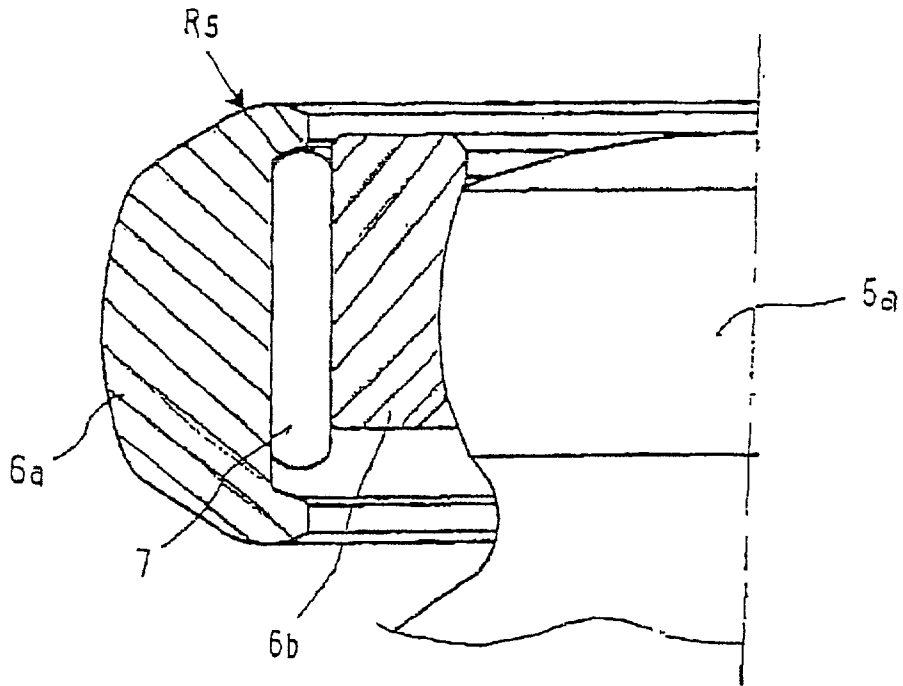

Fig. 17

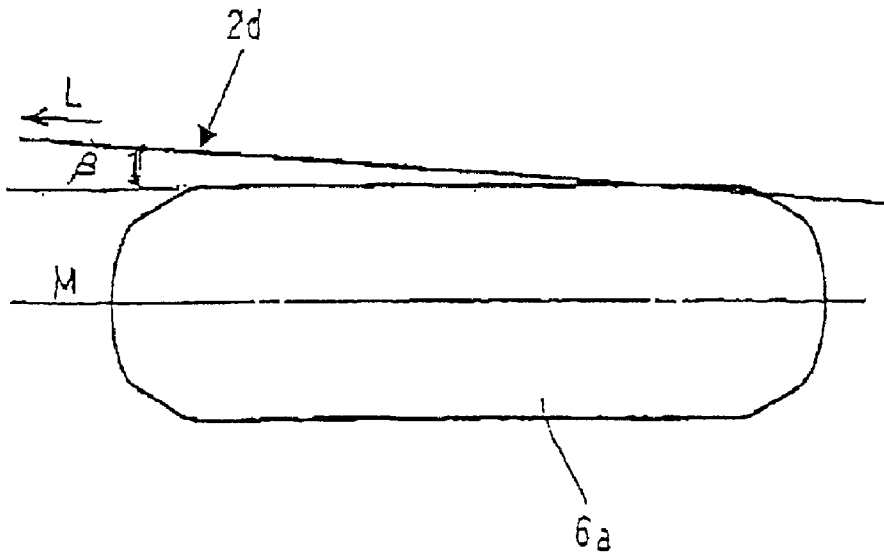

Fig. 18

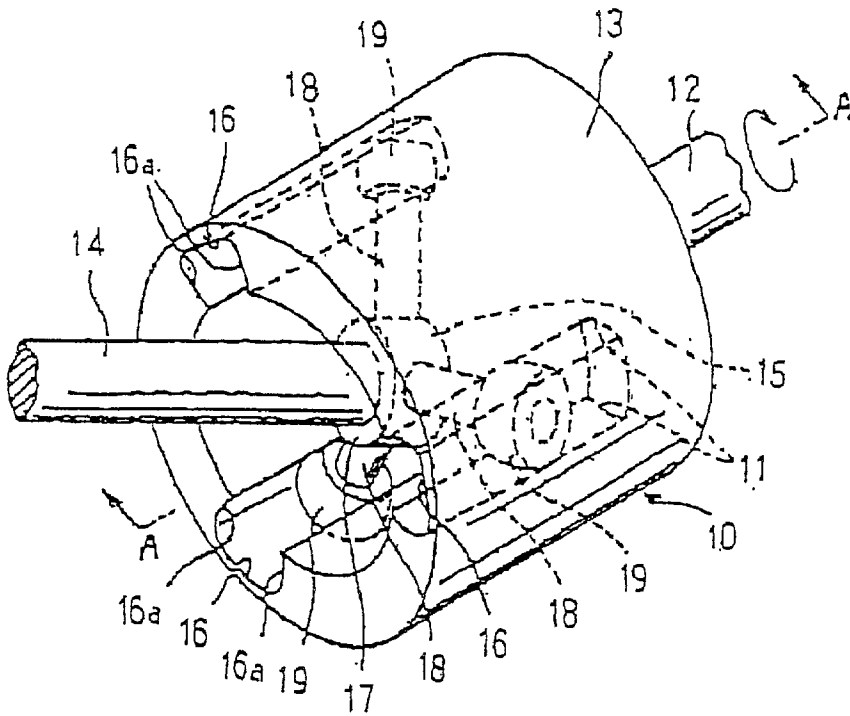

Fig. 19

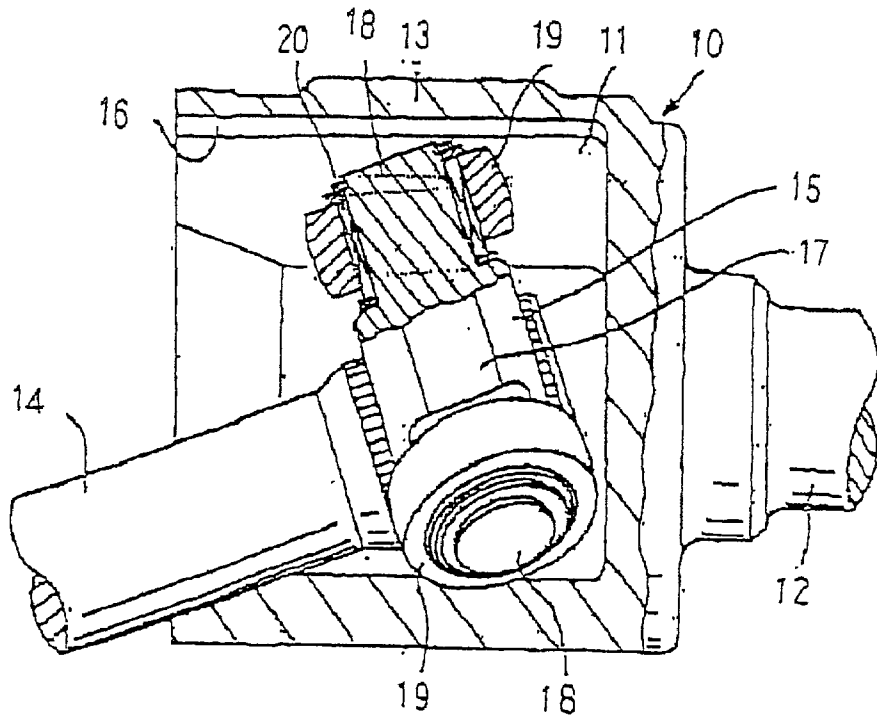

Fig. 20

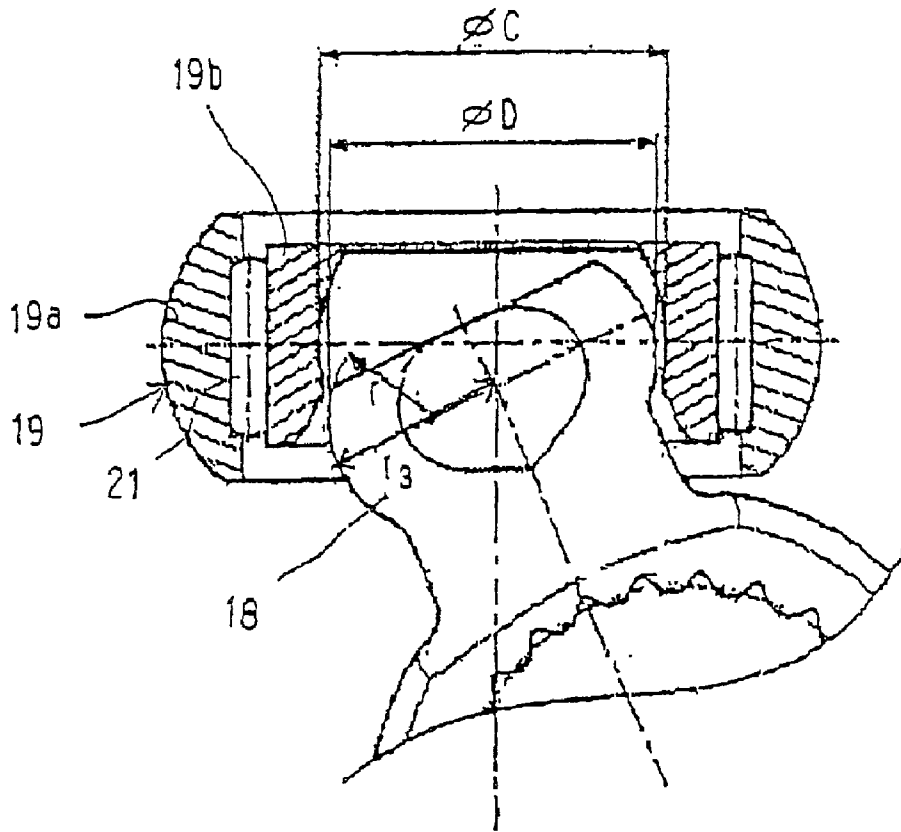

Fig. 21

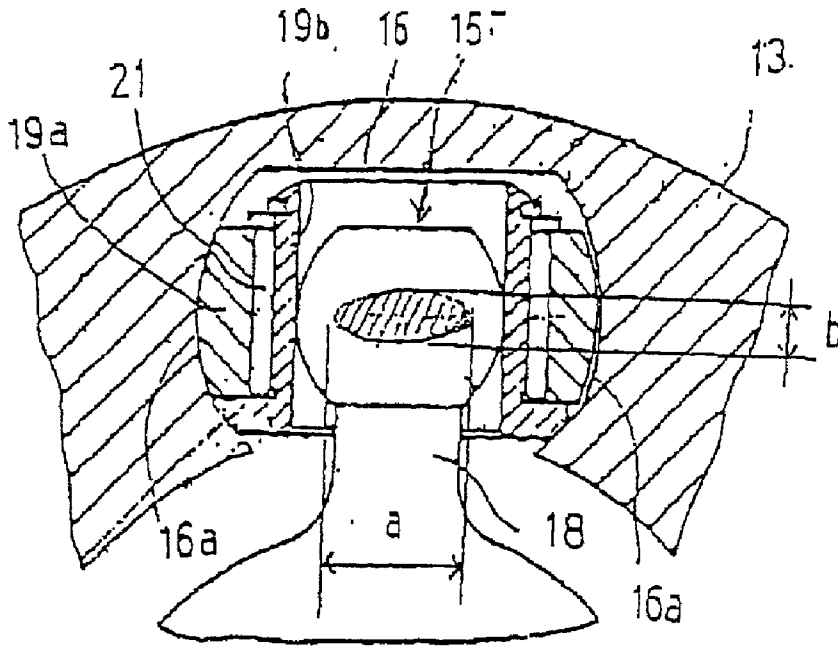
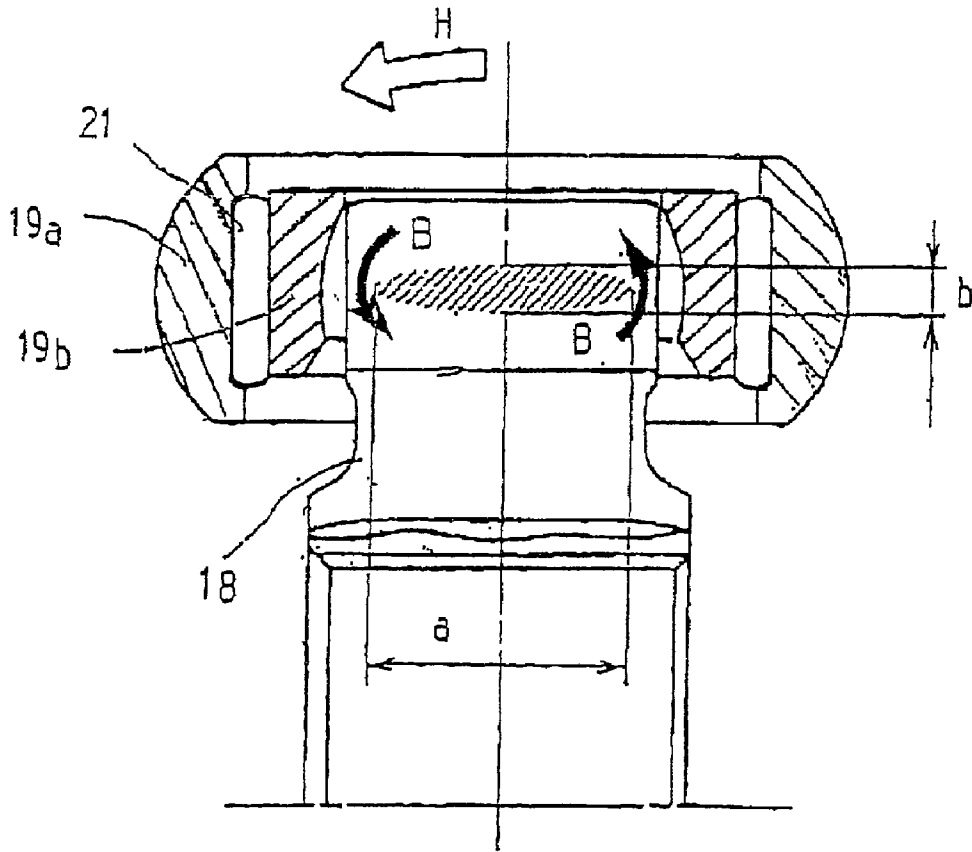

Fig. 22



CONSTANT VELOCITY JOINT OF TRIPOD TYPE

FIELD OF THE INVENTION

[0001] The present invention relates to a tripod type constant velocity joint, which is disposed between rotating shafts connected at a joint angle with each other in a drive axle of, for example, an automobile, for transmitting a rotational torque.

BACKGROUND OF THE INVENTION

[0002] Tripod type constant velocity joints are one of a number of types of constant velocity joints used in drive axles of, for example, automobiles.

[0003] For example, Japanese Laid Open Patent Application Nos. S63(1988)-186036 and S62(1987)-233522 disclose a tripod type constant velocity joint **1**, as shown in **FIGS. 18 and 19** (A-A cross sectional view of **FIG. 18**). This constant velocity joint **10** is provided with a hollow cylindrical housing **13** which is secured to an end of a first rotating shaft **12** serving as a drive shaft or the like on the differential gear side, and a tripod **15** which is secured to an end of a second rotating shaft **14** serving as driven shaft or the like on the wheel side. Grooves **16** are formed at three locations on the internal face of the housing **13** at an even spacing in the circumferential direction and extend outwardly in the radial direction of the housing **13** from said internal face.

[0004] On the other hand, the tripod **15** secured at one end of the second rotating shaft **14** comprises a unified form of a boss **17** for supporting the tripod **15** at one end of the second rotating shaft **14**, and cylindrical trunnions **18** extending radially from three locations at equal spacing around the boss **17** in the circumferential direction. Around the tip end of the respective trunnions **18**, rollers **19** are rotatably supported through a needle bearing **10**, while allowing the rollers to be displaced in the axial direction by certain distances. A tripod type constant velocity joint **10** is provided by engaging the respective rollers **19** with the respective guide grooves **16** on an inner face of the housing **13**. The respective pairs of side faces **11**, on which each of the above guide grooves **16** is provided, are formed to circular recesses. Accordingly, each of the rollers **19** is rotatably and pivotably supported between the respective pairs of the side faces **11**.

[0005] When the constant velocity joint **10** as described above is used, for example, the first rotational shaft **12** is rotated. The rotational force of the first rotational shaft **12** is, from the housing **13**, through the roller **19**, the needle bearing **20** and the trunnion **18**, transmitted to the boss **17** of the tripod **15**, thereby rotating the second rotational shaft **14**. Further, if a central axis of the first rotational shaft **12** is not aligned with that of the second rotational shaft **14** (namely, a joint angle is not zero in the constant velocity joint **10**), each of the trunnion **18** displaces relative to the side face **16a** of each of the guide groove **16** to move around the tripod **15**, as shown in **FIGS. 18 and 19**. At this time, the rollers **19** supported at the ends of the trunnions **18** move along the axial directions of the trunnions **18**, respectively, while rolling on the side faces **16a** of the guide grooves **16**, respectively. Such movements ensure that a constant velocity between the first and second rotational shafts **12** and **14** is achieved.

[0006] If the first and second rotational shafts **12** and **14** are rotated with the joint angle present, in the case of the constant velocity joint **10** which is constructed and operated as described above, each of the rollers **19** moves with complexity. For example, each of the rollers **19** moves in the rotational axis **12** of the housing **13** along each of the side faces **16a** of the respective guide grooves **16**, while the orientations of the rollers **19** are being changed and further the rollers **19** displace in the axial direction of the trunnion **18**. Such complex movements of the rollers **19** cannot cause a relative movement between a peripheral outside face of each of the rollers **19** and each of the side faces **16a** of the guide grooves **16** to be smoothly effected. Thus, a relatively large friction occurs between the faces. As a result, in the constant velocity joint **10**, three-directional axial forces occurs per one rotation. It is known that an adverse oscillation referred to as "shudder" may occur in some cases, if a large torque is transmitted with a relatively large joint angle present.

[0007] In order to solve the above problem, FR275280 discloses a structure as shown in **FIG. 20** and the Japanese Laid-Open patent application No. H3-172619 discloses a structure as shown in **FIG. 21**. In the structure shown in **FIG. 20**, a roller is guided parallel to a housing groove and a spherical trunnion **18** can swing and pivot around a inner spherical surface of an inner roller **19b**. Further, a contact area between the inner spherical surface of the inner roller **19b** and the trunnion **18** when receiving a torque for a load is shaped to an ellipse having a larger long diameter, because a radius "r" of a longitudinal cross-sectional shape of the spherical trunnion **18** is smaller than a radius "r3" of the trunnion **18**. In the structure shown in **FIG. 21**, a torque for a load is received between an inner cylindrical surface of an inner roller **19b** and a spherical trunnion **18**. Thus, a width (a short diameter) "b" of a contact ellipse shaped therebetween is smaller and a contact length "a" in the circumference of a contact area, which corresponds to a long diameter of the contact ellipse is larger. In fact, the contact ellipse is positioned on the side of the trunnion **18** facing with the side face **16a** of the guide groove **16**, although the contact ellipse is shown at the front side for clarification in **FIG. 21**. When these joints rotate with joint angles present upon receiving loads, as shown in **FIG. 22**, a pivotal movement (of a direction indicated by an arrow "H") of the trunnion **18** causes a pivotal sliding action to be occurred on the contact ellipse. Then the pivotal sliding action operates as a spin moment (of a rotational direction indicated by arrows "B") so as to change a rolling direction of the roller assembly **19** comprising the inner roller **19b** and the outer roller **19a**, which are assembled together via a needle bearing **21**. As a result, the direction of the roller assembly **19** is changed until it is in contact with inner or outer face of the guide groove **16**, and in addition a contact force is increased. Moreover, the roller assembly **19** displaces not to be parallel to the guide groove **16**. Hence, it is difficult for the roller assembly **19** to be smoothly rolled, bringing about a significant rolling resistance.

[0008] It is contemplated to enlarge a difference between an inner diameter of the inner roller **19b** and an outer diameter of the trunnion **18**, in order to reduce the long diameter "a" of the contact ellipse. In this case, however, there is raised a new problem in which the joint fluctuates when moving along the rotational direction.

SUMMARY OF THE INVENTION

[0009] The object of the present invention is to overcome the above disadvantages of prior art, that is, to provide a tripod type constant velocity joint having a simple structure which is both highly strong and durable, which can diminish a spin moment acting on the contact ellipse formed between the outer face of the trunnion and the inner face of the inner roller, due to the pivotal sliding movement of the trunnion axis, and which can minimize a rolling resistance when rotating with any joint angle present.

[0010] To solve the above problems, according to the invention, a constant velocity joint of tripod type comprises:

[0011] A cylindrical hollow housing defining an opening at one end, and being secured at its opposite end to a first rotating shaft such that a central axis of the housing is aligned with that of the first rotating shaft, an inner face of the housing being provided with three guide grooves extending in a axial direction of the housing and being spaced apart equally in a circumferential direction, each groove having a pair of side faces opposed to each other, extending in the axial direction, and a bottom portion connecting between the side faces; and

[0012] A tripod provided at an angle normal to a second rotating shaft and secured to one end of the second rotating shaft, the tripod having three trunnions positioned in the grooves, the trunnions being spaced apart equally in a circumferential direction and securing equally to the second rotating shaft at an angle normal, with respective inner rollers being mounted to outside end portions of respective trunnions, and with respective outer rollers being mounted on the outer faces of inner rollers through a needle bearing, the outer faces of the outer rollers being shaped so as to allow movement only in an axial direction of the guide grooves, the side faces receiving a load, and a part of the bottom portion guiding the rolling of the outer roller.

[0013] The constant velocity joint of tripod type is characterized in that, the inner rollers have a spherical inner circumferential surface, respectively; and

[0014] The trunnions have an elliptical shape in the sectional view normal to each of their axes, respectively and is positioned so that the short diameter of the ellipse is substantially parallel to the second rotating shaft.

[0015] According to the invention as constructed above, elliptical contact areas formed in transmitting torque between the inner spherical face of the inner roller and the outer face of the generally spherical trunnion can be maintained relatively small without significant fluctuations during rotating. Thus, it is possible to diminish a spin moment acting on the contact ellipse due to the pivotal sliding movement of the trunnion axis. Accordingly, the invention can bring about advantages including a relatively small contact force between the outer roller and the guide groove, a stable rolling of the outer roller, a smaller rolling resistance and a lower axial force of the joint.

[0016] These and other objects and advantages of the present invention will be more apparent from the following detailed description and drawings in which:

BRIEF DESCRIPTION OF THE DRAWINGS

[0017] The presently preferred embodiment of the invention is disclosed in the following description and in the accompanying drawings, wherein:

[0018] FIG. 1 shows cross-sectional views showing the first embodiment of the present invention, wherein FIG. 1(a) is a longitudinal cross-sectional view and FIG. 1(b) is a side cross-sectional view.

[0019] FIG. 2 is a cross-sectional view of a trunnion axis taken along the line Y-Y.

[0020] FIG. 3 consists of views showing the trunnion axis of FIG. 1, wherein FIG. 3(a) is a partial view thereof and FIG. 3(b) is a side view thereof seen from the side of the guide groove.

[0021] FIG. 4 is an explanatory view showing a relationship regarding location between the trunnion axis and the inner roller.

[0022] FIG. 5 is an explanatory view showing a configuration projected from a direction inclined by an angle α , of the trunnion axis.

[0023] FIG. 6 is a cross-sectional view of the inner roller.

[0024] FIG. 7 is an explanatory view showing the relationship regarding location between the trunnion axis and the inner roller with the inner roller inclined by an angle α .

[0025] FIG. 8 is a partial longitudinal sectional view of the third embodiment of the roller and the trunnion axis.

[0026] FIG. 9 is a partial longitudinal sectional view of the fourth embodiment of the roller and the trunnion axis.

[0027] FIG. 10 is a partial longitudinal sectional view of the fifth embodiment of the constant velocity joint.

[0028] FIG. 11 is an explanatory view showing a state in which a center of the trunnion axis of the fifth embodiment is offset.

[0029] FIG. 12 is an explanatory view showing a load force acting in the fifth embodiment.

[0030] FIG. 13 is a partial longitudinal sectional view of the sixth embodiment of the roller and the trunnion axis.

[0031] FIG. 14 is a partial longitudinal sectional view of the seventh embodiment of the roller and the trunnion axis.

[0032] FIG. 15 is a partial longitudinal sectional view of the eighth embodiment of the inner roller and the trunnion axis.

[0033] FIG. 16 is a partial longitudinal sectional view of the ninth embodiment of the roller and the trunnion axis.

[0034] FIG. 17 is an explanatory view showing a configuration in which the outer roller is inclined relative to the side face of the guide groove by an angle β .

[0035] FIG. 18 is a perspective view of a conventional tripod type constant velocity joint.

[0036] FIG. 19 is a side cross-sectional view of a conventional tripod type constant velocity joint.

[0037] FIG. 20 is an explanatory view showing a relationship regarding location between a conventional trunnion axis and inner roller.

[0038] FIG. 21 is a partial longitudinal sectional view showing a contact ellipse of a conventional tripod type constant velocity joint.

[0039] FIG. 22 is an explanatory view showing a spin moment generating in a conventional tripod type constant velocity joint.

DESCRIPTION OF THE PREFERRED EMBODIMENTS

[0040] The first embodiment of the present invention will be described with reference to the drawings. FIG. 1 shows cross-sectional views of a tripod type constant velocity joint according to the first embodiment of the present invention; wherein, FIG. 1(A) is a longitudinal cross-sectional view, and FIG. 1(B) is a side cross-sectional view. FIG. 2 is a cross-sectional view of the trunnion axis taken along the line Y-Y of FIG. 1. FIG. 3 shows views of a trunnion axis shown in FIG. 1; wherein FIG. 3(A) is a partial view thereof and FIG. 3(A) is a side view thereof seen from the side of a guide groove. FIG. 4 is an explanatory view showing the relationship regarding location between the trunnion axis and the inner roller. FIG. 5 is an explanatory view showing a configuration projected from a direction inclined by an angle α , of the trunnion axis. FIG. 6 is a cross-sectional view of the inner roller. FIG. 7 is an explanatory view showing the relationship regarding location between the trunnion axis and the inner roller with the inner roller inclined by an angle α .

[0041] FIG. 1 shows a cross sectional shape of a tripod type constant velocity joint 1. A tripod 5 is fixedly engaged with a tip end of a second rotating shaft 4 such as a rotational shaft of a wheel, and comprises a boss 7 secured to the second rotating shaft 4 for supporting the tripod 5, and three trunnion axes 5a being integrally formed at equal spacings around the boss 7 in the circumferential direction and extending in the radial direction from the boss 7. As shown in FIG. 2, each of the trunnion axes 5a has an elliptical shape in the sectional view (a cross section) normal to each center of the trunnion axes, which is symmetric with respect to each center of the trunnion axes. Each of these ellipses has a short diameter B which is in the direction of the second rotational shaft 4 and a long diameter A which is in the direction normal to the short diameter, namely, the direction for receiving a torque for a load. The outer face of each of the trunnion axes 5a has a generally spherical shape whose center is aligned with each center of the trunnion axes 5a, on the cross section passing through each center of the trunnion axes 5a and being normal to the second rotational shaft 4, and planes close to the cross section.

[0042] A roller assembly 6 is mounted to each of the trunnion axes 5a. The roller assembly 6 is a double-roller type which has an outer roller 6a, an inner roller 6b, and needle bearing 7 provided between the outer and inner rollers. The inner roller 6b has a generally spherical inner face, which is in contact with the generally spherical outer surface of each trunnion axis 5a. At least one rim 6a1 is formed integral with the outer roller, around one or both circumferential ends of inner face of the outer roller 6a to provide a needle roller stopper. The inner roller 6b is movable in the trunnion axial direction relative to the outer roller 6a. Alternatively, one rim 6a1 may be integral with either of both circumferential ends of inner face of the outer roller 6a, and the other rim 6a1 may be a separate member.

[0043] The tripod 5 is housed in a cylindrical hollow housing 2 defining an opening at one end, and being secured

at its opposite end to a first rotating shaft 8. An inner face of the housing 2 is provided with three guide grooves 2a (formed at locations corresponding to the roller assemblies 6) extending in the direction of the first rotational shaft 8 and being spaced apart equally in a circumferential direction of the housing 2. The roller assemblies 6 are rotatably and movably received in the guide grooves 2a corresponding thereto, respectively. Each of the guide grooves 2a has a pair of side faces 2a, 2a for receiving a load and a bottom portion 2b connecting between the side faces 2a, 2a. A portion of the bottom portion 2b is provided with a tracking guide 2d for guiding the outer roller 6a.

[0044] In the trunnion axis 5a, as shown in FIG. 3(A), an axial width of the generally spherical face of the trunnion is set to a range (the hatched portion) determined in accordance with the relationship $5^\circ \leq \theta$, wherein θ is the angle of a line connecting between the center of the trunnion and one edge of height h, relative to a cross section passing through the center of the height h, and h is the height of the generally spherical face which receives a load on the cross section (longitudinal cross section) which passes each of the trunnion axis 5a and normal to the second rotating shaft 4.

[0045] In the above-mentioned structure, the cross section normal to the trunnion axis 5a is shaped to an ellipse and the direction of its short diameter is arranged parallel to the guide groove 2. Thus, as shown in FIG. 3(B), a contact ellipse (hatched contact patch) is formed in transmitting a torque between the inner spherical face of the inner roller 6b and the generally spherical contact portion of the trunnion axis 5a and the long diameter of the contact ellipse may be relatively small without substantial fluctuations of the joint. Accordingly, a spin moment generated due to a pivotal movement of the trunnion axis 5a can be decreased. In this way, it is possible to prevent the outer roller 6a from contacting the tracking guide 2d of the groove 2 strongly, thereby bringing about a smaller rolling friction of the outer roller 6a and less axial force.

[0046] As shown in FIG. 3(A), an axial width of the generally spherical face of the trunnion axis 5a is set to a range (the hatched portion) determined in accordance with the relationship $5^\circ \leq \theta$, namely, a range receiving a load on the outer face of the trunnion axis 5a, wherein θ is the angle of a line connecting between the center of the trunnion and one edge of height h, relative to a cross section passing through the center of the height h. Accordingly, it is possible to provide a relatively wide area for face contact around the range receiving the load.

[0047] Since the trunnion axis 5a has an elliptical feature in the cross sectional view normal to the trunnion axis as shown in the FIG. 4, even if the inner roller 6b has an inner diameter C which is very close to the long diameter A of the contact ellipse formed on the trunnion 5a to minimize fluctuations of the joint, it is also possible to assemble the joint by pressing the inner roller 6b onto the trunnion axis 5a with elastic deformation of the inner roller. However, in this case, the relationship $d > B$ should exist, wherein d is the short diameter of the inner roller 6b elastically deformed and B is the short diameter of the ellipse of the trunnion axis 5a.

[0048] In this way, according to the embodiment, the rolling resistance of the outer roller 6a and a load acting on the trunnion axis can be decreased and thus an impact on the

joint itself becomes smaller. Therefore, it is possible to provide a tripod type constant velocity joint which is both highly strong and durable.

[0049] In an example, where the cross-sectional shape of the trunnion axis **5a** is not a ellipse but a circle, and both sides are provided with respective planes as shown in **FIG. 20** (the prior art (FR2752890)), it is necessary that the diameter **D** of the trunnion **5a** is close to the inner diameter **C** of the inner roller **6b** in order to minimize any fluctuation in the rotational direction. In such an example, if the inner roller **6b** is strongly pressed onto the trunnion axis **5a**, as shown in **FIG. 4**, a force necessary to press is to excess since four ends of the two planes may interfere with the inner roller **6b**, and hence there is a possibility that the inner roller is damaged. On the contrary, if the diameter **D** of the trunnion **5a** is made to be smaller, the fluctuations in the rotational direction become larger. The present invention, by making the trunnion axis **5a** to be an ellipse shape in the cross section normal to the trunnion axis, these problems can be solved at the same time.

[0050] Next, the second embodiment will be described. This embodiment is almost same as the first embodiment, and so the same reference numbers are used for indicating the same components. The difference between the embodiments, as shown in **FIG. 5**, is that; long diameters **A1** and **A2** (shown in **FIG. 3(A)**) of ellipses at both ends of a generally spherical area of the trunnion axis **5a** are somewhat smaller so that the diameter **A** of the projected curve of the trunnion on a plane inclined α° relative to the plane normal to the trunnion axis can be smaller than the diameter **d** of the inner roller at the side to be pressed onto the trunnion, as in the **FIG. 6**.

[0051] According to the above structure, as shown in **FIG. 6**, even if the inner spherical diameter **C** of the inner roller **6b** is close to the long diameter **A** of the ellipse of the trunnion axis **5a**, as shown in **FIG. 7**, it is easy to assemble the inner roller **6b** to the trunnion axis **5a**, by rotating the inner roller **6b** in the rotational direction indicated by the arrow with the inner roller **6b** inclined by α° .

[0052] The third embodiment will be described with reference to **FIG. 8**. This embodiment is almost same as the first embodiment, and so the same reference numbers are used for indicating the same components. The difference between the embodiments, as shown in **FIG. 8**, is that a retainer **6a3** and a needle stopper ring **8** are provided around both circumferential ends of an inner cylindrical area of the outer roller **6a** to provide a function as a needle stopper for preventing the needle bearings **7** from being detached. The retainer **6a3** and the needle stopper ring **8** are constructed so that the needle stoppers (rim) of the first embodiment may be modified to separate members.

[0053] The fourth embodiment will be described with reference to **FIG. 9**. This embodiment is almost same as the first embodiment, and so the same reference numbers are used for indicating the same components. The difference between the embodiments, as shown in **FIG. 9**, is that rims **6b1** and **6b2** are provided integral with the inner roller **6b**, around both circumferential ends of an outer cylindrical area of the inner roller **6b** to provide a function as a needle stopper. Accordingly, the number of the components can be reduced. Alternatively, it is also possible to constitute a

structure wherein only a single rim, either **6b1** or **6b2**, is formed to be integral with the inner roller **6b** and the other rim is a separate member.

[0054] The fifth embodiment will be described with reference to **FIGS. 10 and 11**. This embodiment is almost same as the first embodiment, and the same reference numbers are used for indicating the same components. The difference between the embodiments, as shown in **FIG. 10**, is that the inner shape of the side face **2a** at the side receiving a load of the guide groove of the housing **2** and the outer shape of the outer roller **6a** are formed to a R-like shape so that they may engage with each other, and in addition, an offset δ is set to the following range, where the offset δ is defined as an offset between the spherical center **M** of the trunnion axis **5a** and the center **N** of inner face of the bottom portion **2c** of the guide groove **2a**, with a joint angle being zero, and **Ro** is defined as a radius of the longitudinal cross section of the outer roller **6a**.

$$0.02R_o < \delta < 0.093R_o$$

[0055] When the constant velocity joint of the first embodiment is rotating with a joint angle present, the spherical center **M** of the trunnion axis **5a** shifts along the axial direction perpendicular to the trunnion axis **5a** relative to the center **N** of the outer face of the outer roller **6a** as shown in **FIG. 11**. If there is a large offset toward the inside of the joint from the center of the side face **2a** of the guide groove to the spherical center **M** of the trunnion axis **5a** with a joint angle being zero, the offset is more increased as the joint angle is more large. In such a situation, as shown in **FIG. 12**, a load (arrow **F**) between the trunnion axis **5a** and the roller assembly **6** acts on a position largely offset from the centerline **N** of the side face **2a** of the guide groove. Thus, a counter clockwise moment is acted on the outer roller **6a** in the direction indicated by arrow "E" in **FIG. 12**. This moment causes the side face **2a** of the guide groove to be strongly in contact with the outer face of the outer roller **6a** at the point on inner side of the joint, thereby bringing about a resistance against the roller **6**, which would be desirable to be avoided.

[0056] In the fifth embodiment of the present invention, the offset (δ) between the trunnion spherical center **M** and the groove centerline **N** is set to be $0.02R_o < \delta < 0.093R_o$, with a joint angle being zero, where **Ro** is a radius of outer face **R** of outer roller **6a**. Therefore, it is possible to eliminate a generation of excessive moment (arrow **E**) on the outer roller **6a** to avoid a strong contact between the side face **2a** of the groove and the outer face of the outer roller **6a** at the opposite side of the loaded side, and to attain obtain a less axial force and a smaller rolling resistance of the outer roller **6a**.

[0057] Next, the sixth embodiment will be described with reference to **FIG. 13**. This embodiment is almost same as the first embodiment, the same reference numbers are used for indicating the same components. The difference between the embodiments, as shown in **FIG. 13**, is that the relationship of ($R1 < R2$) exists where **R1** is an inner diameter of the rim **6a2** formed on the end of the inner surface of the outer roller **6a** and **R2** is an outer diameter of the inner roller **6b**.

[0058] According to the above structure in which the relationship ($R1 < R2$) exists, once the roller assembly comprising the inner roller **6b**, the needle bearings **7** and the

outer roller **6a** is assembled to the trunnion axis **5a**, it is substantially impossible for the outer roller **6a** to be detached from the inner roller **6b**. Additionally, even if the outer roller **6a** moves downward in the drawing, it is substantially impossible for the needle bearings **7** to be detached, since the rims **6a2** engage with the boss **5b** of the trunnion **5a**, and thus it becomes easy to handle the joint.

[0059] Next, the seventh embodiment will be described with reference to **FIG. 14**. This embodiment is almost same as the first embodiment, and so the same reference numbers are used for indicating the same components. The difference between the embodiments, as shown in **FIG. 14**, is that the relationship of ($R4 < R3$) exists where **R3** is a diameter of the rim **6b1** formed on the end of the outer surface of the inner roller **6b** and **R4** is the inner diameter of the outer roller **6a**.

[0060] According to the above structure in which the relationship ($R4 < R3$) exists, once the roller assembly comprising the inner roller **6b**, the needle bearings **7** and the outer roller **6a** is assembled to the trunnion axis **5a**, it is substantially impossible for the outer roller **6a** to be detached from the inner roller **6b**, and thus it becomes easy to handle the joint.

[0061] Next, the eighth embodiment will be described with reference to **FIG. 15**. This embodiment is almost same as the first embodiment, and so the same reference numbers are used for indicating the same components. The difference between the embodiments, as shown in **FIG. 15**, is that the relationship of $r1 \leq R/2$, $r2 \leq R/2$, and $r2 < r1 \leq 3.8r2$ exists where **r1** is a radius of the longitudinal section of the inner face of the inner roller **6b**, **r2** is a radius of the longitudinal section of the outer face of the trunnion axis **5a**, and **R** is the maximum diameter of the cross section of the outer face of the trunnion axis **5a**.

[0062] According to the above structure, as shown in **FIG. 15**, spaces "s" are provided between the respective ends of the inner face of the inner roller **6b** and the respective ends of the spherical face of the trunnion axis **5a**. The spaces act as a sufficient grease-entry space to provide a better durability and a smooth operation. When the joint is rotated with any joint angle present, the inner face of the inner roller **6b** engages with the spherical face of the trunnion axis **5a** in their entirety, bringing about a pivotal movement of the trunnion axis **5a** which may be absorbed only by sliding between the inner face of the inner roller **6b** and the spherical face of the trunnion axis **5a**. In the eighth embodiment, the pivotal movement of the trunnion axis **5a** may be absorbed while the trunnion axis **5a** rolls on the inner face of the inner roller **6b**, because the radius **r1** of the longitudinal section of the inner face of the inner roller **6b** is set to be larger than the radius **r2** of the longitudinal section of the outer face of the trunnion axis **5a**. Accordingly, a frictional resistance can be diminished.

[0063] The ninth embodiment will be described with reference to **FIG. 16**. This embodiment is almost same as the first embodiment, and so the same reference numbers are used for indicating the same components. The difference between the embodiments, as shown in **FIG. 16**, is that the outer ends of the outer roller **6a** have a curved surface **R** which is in contact with the guide groove **2a** of the housing **2** and is then guided by the same, and which is continuously connected from a central portion of the outer face of the outer roller **6a**.

[0064] According to the above structure, as shown in **FIG. 15**, When the constant velocity joint is rotated with any joint angle present, the outer roller **6a** is guided by on the guide groove **2a** and rolls parallel thereto. At this time, as shown in **FIG. 17**, the outer roller **6a** is guided by the tracking guide **2d** with the outer roller **6a** inclined by an angle β relative to the tracking guide **2d**. A curved surface **R5** formed on the outer end of the outer roller **6a** can avoid an edge contact with the tracking guide **2d** and thus reduce a resistance against rolling of the outer roller.

[0065] As described above, according to the present invention, a shape of a cross section of the trunnion axis **5a** normal to its axis is a ellipse whose short diameter is arranged parallel to the rotational axis of the tripod. A contact ellipse is formed between the inner spherical face of the inner roller and trunnion axis and a long diameter of the contact ellipse can be maintained relatively small without significant fluctuations during rotating. Thus, it is possible to diminish a spin moment acting on the contact ellipse due to the pivotal sliding movement of the trunnion axis. Additionally, it can be avoided that the outer roller **A** is in contact with the tracking guide **2d** as strongly as unnecessary.

[0066] Accordingly, the invention can attain a stable rolling of the outer roller, a smaller rolling resistance and a lower axial force of the joint, and a provision of a tripod type constant velocity joint which is both highly strong and durable.

[0067] Moreover, according to the invention, it is possible to reduce any oscillation of a vehicle when the tripod type constant velocity joint of the invention is mounted to the vehicle.

[0068] The disclosed embodiment is representative of a presently preferred form of the invention, but is intended to be illustrative rather than definitive thereof. The invention is defined in the claims.

What is claimed is:

1. A constant velocity joint comprising:

a hollow housing having an opening at one end, and being secured at its opposite end to a first rotating shaft such that a central axis of the housing is aligned with that of the first rotating shaft, an inner face of the housing being provided with three guide grooves extending in an axial direction of the housing and being spaced apart equally in a circumferential direction, each groove having a pair of side faces opposed to each other, extending in the axial direction, and a bottom portion connecting between the side faces; and

a tripod provided at an angle normal to a second rotating shaft and secured to one end of the second rotating shaft, the tripod having three trunnions positioned in the grooves, the trunnions being spaced apart equally in a circumferential direction and securing equally to the second rotating shaft at an angle normal, with respective inner rollers being mounted to outside end portions of respective trunnions, and with respective outer rollers being mounted on the outer faces of inner rollers through a needle bearing, the outer faces of the outer rollers being shaped so as to allow movement only in an axial direction of the guide grooves, the side faces receiving a load, and a part of the bottom portion guiding the rolling of the outer roller;

the inner rollers having a spherical inner circumferential surface, respectively; and

the trunnions having an elliptical shape in the sectional view normal to each of their axes, respectively and positioned so that the short diameter of the ellipse is substantially parallel to the second rotating shaft.

2. A constant velocity joint, comprising:

a hollow housing having an open end and an inner face formed with three axially extending circumferentially spaced guide grooves;

a tripod having a tripod axis disposed in said housing and including three circumferentially spaced trunnions extending radially outwardly of said tripod axis along respective trunnion axis into said guide grooves;

a roller assembly carried on each of said trunnions within said guide grooves and supported for rotational, angular and axial movement relative to said trunnions; and

wherein said trunnions each have an outer surface of elliptical shaped in a section taken normal to said respective trunnion axes with a minor diameter of the ellipse being parallel to said tripod axis.

3. The constant velocity joint of claim 1 wherein each of said roller assemblies includes an inner surface engaging said outer surface of said trunnion, said inner surface being part spherical.

4. The constant velocity joint of claim 1 wherein each of said roller assemblies includes an inner roller having an inner surface that is part spherical with a small diameter d at one end of said roller and a maximum diameter C spaced

from said one end, said small diameter d being less than said major diameter of said elliptically shaped trunnions.

5. The constant velocity joint of claim 1 wherein each of said roller assemblies includes an inner roller having an inner surface that is part spherical with a small diameter d at one end of said roller and a maximum diameter C spaced from said one end, each of said trunnions having a projection diameter A measured at an assembly angle α .

6. The constant velocity joint of claim 5 wherein $d < A$.

7. The constant velocity joint of claim 5 wherein $d \geq A$.

8. A method of installing a roller assembly of a tripod constant velocity joint on a trunnion of the joint having an elliptical outer surface in a section taken normal to a trunnion axis, comprising:

aligning the roller assembly with the trunnion; and

forcing the roller assembly onto the trunnion causing the roller assembly **6** to deform elastically during installation and to return following installation.

9. A method of installing a roller assembly of a tripod constant velocity joint on a trunnion of the joint having an elliptical outer surface in a section taken normal to a trunnion axis, comprising:

tilting the roller assembly relative to the trunnion axis; and

guiding the roller assembly onto the trunnion while so tilted.

* * * * *